

OPTRONIC LABORATORIES, INC.

Emphasizing Precision and Accuracy

**OL 730D
Programmable DSP Radiometer**

**Manual No: M000164
Revision: F
March 2001**

**This Manual Applies to
Instrument Serial Numbers XX306XXX and above**

A Gooch & Housego Company

OL 730D
Programmable DSP Radiometer

Table of Contents

INTRODUCTION	1
SPECIFICATIONS.....	1
ELECTRICAL / MECHANICAL SPECIFICATIONS.....	1
PERFORMANCE SPECIFICATIONS	2
Signal	2
Reference	2
Analog Outputs (CH1, CH2).....	2
OL 730D FRONT PANEL FUNCTIONS	3
FUNCTION KEYS	3
MENU.....	3
1. EDIT DETECTOR	3
2. SET RESPONSE TIME.....	3
3. SELECT INPUT SOURCE	4
AC CURRENT, AC CPLG	4
AC CURRENT, DC CPLG.....	4
DC CURRENT, DC CPLG.....	4
DC CURRENT STORAGE	4
AC VOLTAGE, AC CPLG	4
AC VOLTAGE, DC CPLG	4
DC VOLTAGE, DC CPLG	4
DC VOLTAGE STORAGE.....	4
PHOTON COUNTING.....	4
4. SELECT MEASUREMENT	4
5. SELECT REFERENCE.....	4
6. SELECT DYNAMIC RESERVE	4
7. SELECT NOTCH FILTERS	5
8. SELECT CH1 OUTPUT.....	5
SIN WAVE REFERENCE	5
COS WAVE REFERENCE	5
x SIGNAL COMPONENT	5
y SIGNAL COMPONENT	5
X SIGNAL COMPONENT	5
Y SIGNAL COMPONENT	5
RESULTANT MAGNITUDE	5
RAW SIGNAL INPUT	5
AVERAGE SIGNAL INPUT	5
AVERAGE AUX INPUT	5
9. SELECT CH2 OUTPUT.....	5
10. NORMALIZE % VALUE	5
11. NORMALIZE dB VALUE.....	5
12. SELECT UPDATE RATE.....	6
13. ERASE DETECTOR.....	6
14. ERASE ALL DETECTORS	6
15. INTEGRATION MODE.....	6
16. TRISTIMULUS MODE	7
17. SET PMT HIGH VOLTAGE	7
18. SET PMT FLUX LIMIT.....	7
19. CLEAR MEM (1-99).....	7
20. ZCAL ALL RANGES	7
21. SET REAL TIME CLOCK.....	8
22. SELECT COM INTERFACE.....	8
23. SET DEVICE ADDRESS.....	8
24. SET BAUD RATE.....	8

OL 730D
Programmable DSP Radiometer

Table of Contents

25. SET TTL I/O.....	8
26. CAL TRISTIMULUS.....	8
27. CAL CHOPPER DRIVER.....	8
28. CAL VOLTAGE PREAMP.....	9
29. CAL CURRENT PREAMP.....	9
REF.....	9
GAIN.....	9
ZERO.....	9
DET.....	9
UNIT.....	9
MEM.....	10
ESC.....	10
(ENTER).....	10
ARROW KEYS.....	10
REAR PANEL CONNECTIONS.....	11
CURRENT INPUT.....	11
VOLTAGE INPUT.....	11
PMT HV OUTPUT.....	11
AUX INPUT.....	11
PREAMP OUTPUT.....	11
CH1 OUTPUT.....	11
CH2 OUTPUT.....	11
AUX INTERFACE.....	11
EXT REF INPUT.....	11
TTL REF OUTPUT.....	11
TTL I/O.....	11
CHOPPER INTERFACE.....	11
IEEE-488.....	11
RS-232.....	11
OPERATION.....	12
AC LOCK-IN MODE.....	13
REFERENCE.....	13
1. Internal Reference.....	13
2. Chopper Reference.....	13
3. External Reference.....	14
DYNAMIC RESERVE.....	14
AC/DC COUPLING.....	14
MEASUREMENT TYPE.....	14
NOTCH FILTERS.....	15
DC MODE.....	15
PHOTON COUNTING MODE.....	15
TTL INPUT/OUTPUT.....	16
DETECTOR SETUP LIBRARY.....	17
MEMORY HOLD MODES.....	19
STORE.....	19
RECALL.....	19
EXIT FROM MEMORY HOLD.....	19

OL 730D
Programmable DSP Radiometer

Table of Contents

% or DB UNITS	20
OL 730D-HV PMT HIGH VOLTAGE SUPPLY	21
SETTING THE PMT VOLTAGE	21
SETTING THE PMT FLUX LIMIT	21
TRIGGER DATA MODE	22
DC STORAGE MODE	22
TRISTIMULUS MODE	23
MEASURING CIE 1931 CHROMATICITY COORDINATES	25
ENTERING CALIBRATION FACTORS	25
RS-232C / GPIB INTERFACE	26
COMMAND SET	26
l	26
c	26
D	26
U X	26
G XXX	26
F XXXXX	26
f	26
T XX	26
O X X	27
H X	27
I X	27
K XX	27
Q X	28
Z	28
N	28
V XXXXX	28
E	28
S XX	28
R XXX XX X	28
M XX	28
X XX XX X	29
Y XX XX	29
@	29
P XXXX or P XXXX XXX	30
p	30
J	30
A X X	30
B	30
# X	30
\$	31
% X	31
SYSTEM STATUS BYTE	31
COMMUNICATION PROTOCOL	32
RS-232C	32
RS-232C Connector Pinout	33
GPIB	34

OL 730D
Programmable DSP Radiometer

Table of Contents

VOLTAGE SELECTION	35
WARRANTY	37
Units, Symbols & Equations	Tables 1 to 4
Sample Remote Control Programs	Appendix A
Optional Accessories.....	Appendix B
Detector Setup Library	Appendix C
OL 730D Calibration Certificate	Appendix D
Tristimulus Calculations	Appendix E
CE Conformance Certificate (optional)	

OL 730D Programmable DSP Radiometer

INTRODUCTION

The OL 730D Programmable DSP Radiometer utilizes state-of-the-art Digital Signal Processing (DSP) techniques to give the best performance in all applications. A 16-bit precision analog-to-digital converter is used to generate highly accurate values of the signal every 10 microseconds. The combination of accurate measurements and high sampling rate allows an exact analysis of how the signal varies with time and, consequently, may isolate specific frequency and phase components. Thus the OL 730D may perform as an a.c. or d.c. amplifier without changing the electronics, and can even be used as a photon-counter.

The OL 730D Programmable DSP Radiometer features several modes of operation depending on the type of amplification desired: a.c. lock-in current or voltage, d.c. current or voltage, and photon-counting. These modes have specific operational and support features which are described in their respective sections of this manual. Also, although the OL 730D was designed primarily for use with optical radiation detectors, it is an extremely versatile general laboratory instrument, directly replacing many types of amplifier in one compact easy-to-use unit.

SPECIFICATIONS

ELECTRICAL / MECHANICAL SPECIFICATIONS

Readout (units)	User programmable
Display	4 □ digits plus exponent
Response time	user selectable for each gain range from 0.0033 to 4096 seconds
Zero control	automatically subtracted when pressed
Range selector	auto / manual
PMT DC bias voltage.....	-200 to -1100 VDC (optional)
Computer interface.....	RS-232C std, IEEE-488 (optional)
Size	3.5 inch x 17 inch x 10 inch (9 cm x 43 cm x 25.5 cm)
Weight	10 lbs (4.5 kg)
Power requirements.....	115 VAC 60Hz / 220 VAC 50Hz
Warranty	1 year parts and labor

SPECIFICATIONS

PERFORMANCE SPECIFICATIONS

Signal

Current Input:

Ampere range 3 mA maximum
Input impedance < 0.5 Ω

AC Current Mode:

Ampere range 2×10^{-3} to 2×10^{-10} A (FS)
Display / interface resolution 10^{-14} A
Basic accuracy $\pm (0.1 \% + 2 \text{ digits})$
Bandwidth 10 Hz to 10 kHz (10^{-3} to 10^{-9} ranges)
10 Hz to 350 Hz (10^{-10} range)

DC Current Mode:

Ampere range 2×10^{-3} to 2×10^{-10} A (FS)
Display / interface resolution 10^{-14} A
Basic accuracy $\pm (0.05 \% + 1 \text{ digit})$

Voltage Input:

Voltage range 10 V maximum
Input impedance 10 M Ω

AC Voltage Mode:

Voltage range 2×10^0 to 2×10^{-3} V
Display / interface resolution 10^{-7} V
Basic accuracy $\pm (0.1 \% + 2 \text{ digits})$
Bandwidth 10 Hz to 10 kHz

DC Voltage Mode:

Voltage range 2×10^0 to 2×10^{-3} V
Display / interface resolution 10^{-7} V
Basic accuracy $\pm (0.05 \% + 1 \text{ digit})$

Line filters 50/60 Hz, 100/120 Hz, Q=4
Dynamic reserve 100 dB without pre-filtering
Sampling rate 100 kHz, 16 bit resolution

Reference

Frequency range 10 Hz to 10 kHz
Reference input TTL or sine, 500 mVp-p minimum, " 10 V maximum

Analog Outputs (CH1, CH2)

Gain accuracy " (2 % + 50 mV)
Output current " 10 mA maximum
Output voltage " 10 V maximum

OL 730D FRONT PANEL FUNCTIONS

Figure 1 - OL 730D Front Panel

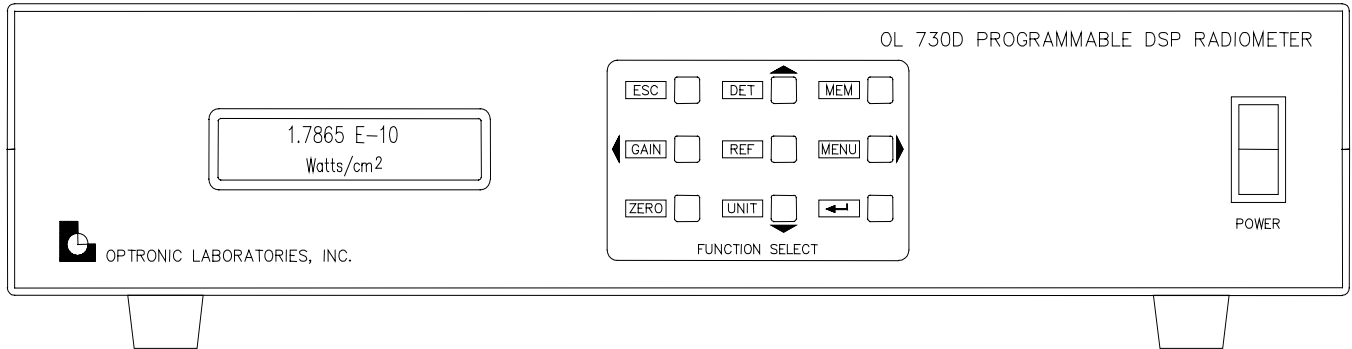

P000596B

FUNCTION KEYS

MENU

The MENU key accesses the various menu selections. Once the MENU key is pressed, the up arrow and down arrow keys are pressed to view the various menu selections available. When the desired selection is displayed, pressing the ENTER key will display the sub-menu for that selection.

Once in the sub-menu, the arrow keys can be pressed to adjust any displayed parameters. Another press of the ENTER key saves the displayed parameters and returns the display to the main menu.

The ESC key is used to exit from any menu without saving any changes.

The main menu options are as follows:

1. EDIT DETECTOR

This selection enables the user to edit the description, units and calibration factor of the presently selected detector. (See the DETECTOR SETUP LIBRARY section.)

2. SET RESPONSE TIME

This selection enables adjustment of the response time of each gain range from 0.1 to 25.5 seconds. When in this sub-menu, pressing the up and down arrow keys scans through the gain ranges and their associated response times. Pressing the ENTER key selects the displayed gain range.

Once a gain range is selected, pressing the up and down arrow keys adjusts the response time. Pressing the ENTER key will store the response time value for that gain range and return the display to the sub-menu.

The maximum integration time limit and resolution depends on the update rate (see menu option 12. SELECT UPDATE RATE).

The response times are factory preset as follows:

Gain	Response Time (seconds)
E-3	0.5
E-4	0.8
E-5	1.0
E-6	1.0
E-7	1.5
E-8	2.0
E-9	2.5
E-10	3.0

OL 730D FRONT PANEL FUNCTIONS

3. SELECT INPUT SOURCE

This option enables the user to select the input source (current, voltage, or photon counter), the measurement method (AC lock-in, DC, or photon counting), and the coupling method (AC or DC), as follows:

AC CURRENT, AC CPLG

Performs AC lock-in measurement of the current at the CURRENT INPUT BNC connector on the rear panel, with AC coupling.

AC CURRENT, DC CPLG

Performs AC lock-in measurement of the current at the CURRENT INPUT BNC connector on the rear panel, with DC coupling.

DC CURRENT, DC CPLG

Performs DC measurement of the current at the CURRENT INPUT BNC connector on the rear panel, with DC coupling.

DC CURRENT STORAGE

Performs DC measurement of the current at the CURRENT INPUT BNC connector on the rear panel, with DC coupling. See the *DC Storage Mode* section.

AC VOLTAGE, AC CPLG

Performs AC lock-in measurement of the voltage at the VOLTAGE INPUT BNC connector on the rear panel, with AC coupling.

AC VOLTAGE, DC CPLG

Performs AC lock-in measurement of the voltage at the VOLTAGE INPUT BNC connector on the rear panel, with DC coupling.

DC VOLTAGE, DC CPLG

Performs DC measurement of the voltage at the VOLTAGE INPUT BNC connector on the rear panel, with DC coupling.

DC VOLTAGE STORAGE

Performs DC measurement of the voltage at the VOLTAGE INPUT BNC connector on the rear panel, with DC coupling. See the *DC Storage Mode* section.

PHOTON COUNTING

Performs counting of the frequency of TTL-level pulses received at the PHOTON COUNTER D-subminiature 9-pin connector on the rear panel.

4. SELECT MEASUREMENT

This option enables the user to select the type of displayed units of AC measurement (RMS, peak, peak-peak). (See the *AC LOCK-IN MODE* section.)

5. SELECT REFERENCE

This option enables the user to select the reference source used for AC measurements. (See the *AC LOCK-IN MODE* section.)

6. SELECT DYNAMIC RESERVE

This option enables the user to select the amount of dynamic reserve that will be applied to AC measurements. (See the *DYNAMIC RESERVE* portion of the *AC LOCK-IN MODE* section.)

7. SELECT NOTCH FILTERS

This option enables the user to switch the notch filters in and out of the signal chain. The 1X filter is tuned to the power line frequency, and the 2X filter is tuned to twice the power line frequency. (See the *Notch Filter* portion of the *AC LOCK-IN MODE* section.)

8. SELECT CH1 OUTPUT

This option enables the user to select the signal to be output on the CH1 OUTPUT BNC connector on the rear panel. The options are:

SIN WAVE REFERENCE

A 10 volt peak sine wave at the reference frequency. (AC mode only)

COS WAVE REFERENCE

A 10 volt peak cosine wave at the reference frequency. (AC mode only)

x SIGNAL COMPONENT

A 10 volt peak, unaveraged, uncalibrated product of the signal and the sine wave reference. (AC mode only)

y SIGNAL COMPONENT

A 10 volt peak, unaveraged, uncalibrated product of the signal and the cosine wave reference. (AC mode only)

X SIGNAL COMPONENT

A 10 volt peak, averaged, uncalibrated product of the signal and the sine wave reference. (AC mode only)

Y SIGNAL COMPONENT

A 10 volt peak, averaged, uncalibrated product of the signal and the cosine wave reference. (AC mode only)

RESULTANT MAGNITUDE

A 10 volt peak, averaged resultant magnitude of the X and Y components. (AC mode only)

RAW SIGNAL INPUT

A 10 volt peak, unaveraged representation of the preamplifier signal.

AVERAGE SIGNAL INPUT

A 10 volt peak, averaged representation of the preamplifier signal. (DC mode only)

AVERAGE AUX INPUT

A 10 volt peak, averaged representation of the AUX INPUT signal.

9. SELECT CH2 OUTPUT

This option enables the user to select the signal to be output on the CH2 OUTPUT BNC connector on the rear panel. The options are the same as for the CH1 OUTPUT.

10. NORMALIZE % VALUE

This option enables the user to normalize the current signal to 100 %.

11. NORMALIZE dB VALUE

This option enables the user to normalize the current signal to 0 dB.

OL 730D FRONT PANEL FUNCTIONS

12. SELECT UPDATE RATE

This option enables the user to select the rate at which the reading is updated. Slower update rates allow longer integration times. (See menu option 2. *SET RESPONSE TIME*.) The maximum integration time and resolution are related to the update rate as follows:

Update Rate (Hz)	Resolution (Seconds)	Maximum Integration Time (Seconds)
2	0.5000	4096.0
10	0.1000	819.2
50	0.0200	50.0
60	0.0167	36.0
300	0.0033	1.4

13. ERASE DETECTOR

This selection enables erasure of the unit, cal factor, etc. of the presently selected detector from the detector setup library.

Pressing the ENTER key will select this option. "ARE YOU SURE?" and the description text will be displayed.

Pressing the ESC key will cancel the erasure. Pressing the ENTER key will perform the erasure.

14. ERASE ALL DETECTORS

This selection enables erasure of the entire detector library.

Pressing the ENTER key will select this option. "ARE YOU SURE ? ALL WILL BE ERASED !" will be displayed.

Pressing the ESC key will cancel the erasure. Pressing the ENTER key will perform the erasure.

15. INTEGRATION MODE

This selection enables the user to switch between normal current-measuring operation and integration mode.

The OL 730D always integrates for 100 mS periods, calculates a value of current measured during that period and updates the display. When in normal operation, the measured values are averaged over a time period determined by the response time setting. When in the integration mode, those measured values are added up until the integration process is halted.

To select integration mode, press the up or down arrow keys until INTEGRATION MODE is displayed and then press the ENTER key. Press the ESC key to exit this menu option.

The top right-most characters of the display will read "CLR". This indicates that the reading has been cleared and the signal is not being integrated.

The bottom right-most characters of the display will read "*S". This indicates that the units are multiplied by the time of integration. If the units are AMPERES, the units become AMPERES*S (= coulombs). If the units are WATTS, the units become WATTS*S (= joules).

Units of % or dB are also allowed in the integration mode. Because these are unitless ratios, the "*S" is only an indication that the integration mode is active.

To integrate a signal:

1. Press the **ZERO** key to null the dark current offset.
2. To begin integration, press the **ENTER** key. "RUN" will display indicating that the signal is being integrated.
3. When the desired period of measurement has elapsed, press the **ENTER** key again to cease integration and freeze the signal reading. "HLD" will be displayed indicating that the reading is in a "hold" mode.
4. To integrate another signal, press the **ENTER** key to clear the current reading. Press the **ENTER** key again to begin a new integration.

16. TRISTIMULUS MODE

This option performs measurement of the CIE 1931 chromaticity coordinates when used with the OL 600 Direct Viewing Imaging Optics Module and the OL 730-5-PF/730-5-T tristimulus filter set. (See the *TRISTIMULUS MODE* section.)

17. SET PMT HIGH VOLTAGE

This option enables adjustment of the optional high voltage PMT supply. (See the *OL 730D-HV PMT HIGH VOLTAGE SUPPLY* section.)

*** WARNING ***

Even when set to "MIN," the HV output is approximately -165 volts!! Turn the power off before connecting or disconnecting the HV supply !!

18. SET PMT FLUX LIMIT

This option enables adjustment of the maximum allowable PMT output. (See the *OL 730D-HV PMT HIGH VOLTAGE SUPPLY* section.)

19. CLEAR MEM (1-99)

This option enables erasure of all 99 memory hold registers. The memory hold registers are also automatically cleared when the unit is powered up. (Refer to the *MEMORY HOLD MODES* section).

20. ZCAL ALL RANGES

This option commands the OL 730D to scan through all the gain ranges and take readings to be used as the zero offsets for each gain range. This provides the utmost in range-to-range offset accuracy. This process takes approximately 1 minute to perform and should be done after the OL 730D is completely warmed up, with the current input open and voltage input shorted.

(The CURRENT INPUT BNC connector on the rear panel should be completely disconnected from all devices and cables, and the VOLTAGE INPUT BNC connector should be shorted to its own ground as close as possible to the connector.)

The readings taken are lost upon power down. The OL 730D will then default to the zero offsets taken when the preamp was calibrated, which are more than adequate for most applications.

The **ZERO** key should be used for overall offset nulling.

OL 730D FRONT PANEL FUNCTIONS

21. SET REAL TIME CLOCK

This selection enables setting of hours, minutes, day and date. Press the up or down arrow keys to adjust the displayed parameter, and press the ENTER key when the desired setting is displayed.

22. SELECT COM INTERFACE

This option enables selection of the standard RS-232C interface or the optional GPIB (IEEE-488) interface. (See the *RS-232C/GPIB INTERFACE* section.)

If the optional GPIB interface is not installed, the bottom line will display "GPIB NOT INSTALLED!".

23. SET DEVICE ADDRESS

This option enables setting the OL 730D's GPIB (IEEE-488) or RS-232C device address. This unique address is used for identifying which messages are intended for this device during communication transfers.

24. SET BAUD RATE

This option enables setting the speed at which the OL 730D's serial interface communicates with a host computer. The baud rates are from 300 to 9600 baud.

25. SET TTL I/O

This option enables manual reading of the TTL inputs and manual reading and setting of the TTL outputs.

When this option is selected, the top line of the display shows the binary states of the TTL trigger inputs, and the bottom line shows the binary states of the TTL outputs, Output 8 - 1, from left to right. Both lines are shown in real-time and will change when remote commands or input voltages change their corresponding I/O states.

Press the up arrow key to set and the down arrow key to clear the TTL output bit indicated by the blinking cursor.

Press the right arrow key to advance the blinking cursor to the next bit.

Pressing ESC will restore the TTL outputs to their previous state and exit the menu option.

Pressing ENTER will exit the menu option without changing the TTL output states.

26. CAL TRISTIMULUS

This option enables entry of the calibration factors for the OL 600 Direct Viewing Imaging Optics Module's optional OL 730-5-PF/730-5-T tristimulus filter set. (See the *TRISTIMULUS MODE* section.)

27. CAL CHOPPER DRIVER

This option enables calibration of the chopper controller. This calibration does not affect the accuracy of the chopper frequency, but it minimizes the time required for the chopper controller to reach the commanded frequency.

This menu option should be performed whenever the chopper blade is changed to one with a different number of apertures.

28. CAL VOLTAGE PREAMP

This option enables display of the calibration date of the voltage preamplifier.

29. CAL CURRENT PREAMP

This option enables display of the calibration date of the current preamplifier.

REF

This key is functional only when the OL 730D is in AC Lock-In mode. This key enables viewing and setting the reference frequency value for AC measurements using the chopper reference or the internal reference. It also enables reviewing only the incoming frequency value when using the external reference input.

For the external reference source:

Pressing the REF key will display the external reference frequency.

For the internal and chopper reference sources:

When using the internal or chopper reference, pressing this key will display the commanded frequency on the top line of the display and the actual frequency on the bottom line of the display.

Pressing the up or down arrows will adjust the commanded reference frequency value. Pressing the ENTER key will store the new value for the commanded reference frequency.

Pressing the ESC key will exit without storing the new value.

The display will next indicate the on/off status of the internal chopper reference source. Pressing the ENTER key will change the on/off status and exit. Pressing the ESC key will exit without changing the on/off status.

GAIN

This key enables selection of the gain range to be used or selection of auto-ranging. After pressing the GAIN key, the up arrow or down arrow key is used to select the gain range.

ZERO

This key performs nulling of the current, voltage, or photon count offset. Any value of current, voltage or count on any range can be nulled. For best results when using manual ranging, the current or voltage should be nulled on the most sensitive range to be used.

DET

This key enables the selection of one of the 25 detector library setups. After pressing the DET key, the up arrow or down arrow key is used to view and select the available detector setup selections.

If nothing has been stored for a particular detector setup, "SETUP NOT DEFINED" will be displayed on the bottom line.

UNIT

This key scans through the four types of displayed units:

- SI units (volt, ampere, or counts/second)
- User-defined units
- % (percent)
- dB (decibels).

If the presently selected detector is not defined (no calibration factor or description), user-defined units cannot be accessed.

Both % and dB are normalized using the *NORMALIZE % dB VALUE* menu option. (See the *% dB UNITS* section.)

OL 730D FRONT PANEL FUNCTIONS

MEM

This key enables the two memory hold modes; STORE and RECALL. Successive presses of this key rotates the display through the STORE, RECALL and normal operating modes. (See the *MEMORY HOLD MODES* section.)

ESC

This key enables escape from the menu options, setup operations, etc.. Pressing the ESC key usually returns the OL 730D to the main operating mode. In certain modes, pressing this key will advance to the next mode without entering any changes.

(ENTER)

The  (ENTER) key is used to accept adjusted parameter input, advance through setup operations, etc.

ARROW KEYS



The ARROW keys are used to scroll through menu selections. Refer to the individual function key descriptions for the context-specific, appropriate usage of the arrow keys.

REAR PANEL CONNECTIONS

Figure 2 - OL 730D Rear Panel

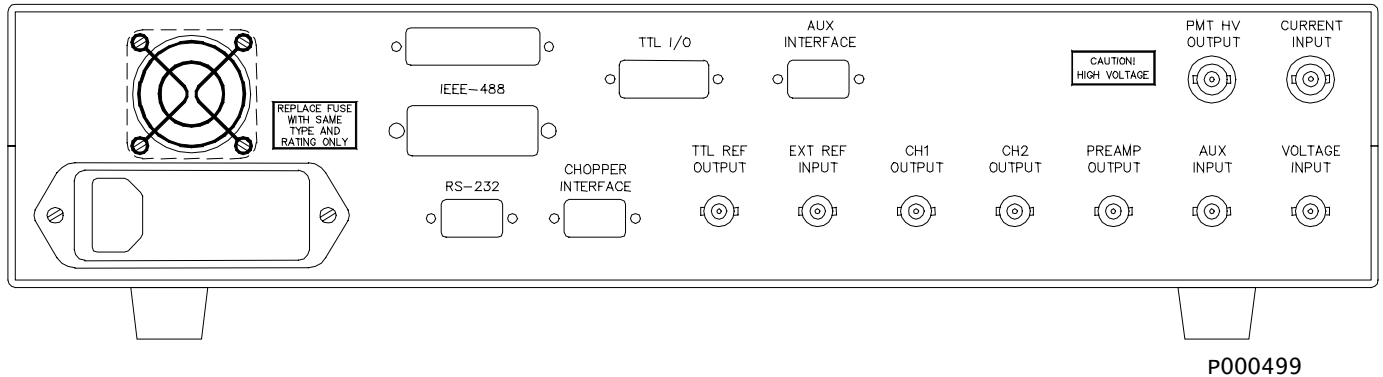

The functions of the rear panel connections are as follows:

CURRENT INPUT

Input to the current preamplifier.

VOLTAGE INPUT

Input to the voltage preamplifier.

PMT HV OUTPUT

Output of the optional OL 730D-HV high voltage supply for use with photomultiplier tubes.

AUX INPUT

Auxiliary DC voltage input.

PREAMP OUTPUT

Voltage output from the preamplifier.

CH1 OUTPUT

Voltage output from the DSP-driven D/A converter #1.

CH2 OUTPUT

Voltage output from the DSP-driven D/A converter #2.

AUX INTERFACE

Interface for the optional photon counter discriminator.

EXT REF INPUT

Input for an analog or TTL reference signal.

TTL REF OUTPUT

Output for TTL level square wave reference signal.

TTL I/O

Provides eight general purpose TTL outputs and two TTL inputs/triggers.

CHOPPER INTERFACE

Provides motor drive and frequency input for the optional optical chopper.

IEEE-488

Optional OL 730D-IEEE488 interface provides IEEE-488 (GPIB) communication.

RS-232

Provides RS-232 communication.

OPERATION

OPERATION

To set up the OL 730D for standard non-PMT voltage or current operation, simply connect the voltage or current to be measured to the voltage or current input and turn the power switch to the ON position. The unit displays the product name and revision level.

**** CAUTION ****

Do not connect source voltages higher than 10 volts! Doing so may cause damage to the instrument!

To ensure that the unit is configured as desired:

1. Press the **DET** key and select the desired detector setup (if any). This is only necessary for using user-defined units.
2. Press the **GAIN** key and select auto-ranging or the manual gain range desired.
3. Press the **UNIT** key until the desired units are displayed.
4. Press the **MENU** key, select the **SET RESPONSE TIME** option, and check the response times for each gain range. Adjust if desired.
5. Select the *SELECT INPUT SOURCE* menu option and select the input source desired.
6. If making an AC lock-in measurement, select the *SELECT MEASUREMENT* menu option and select the type of AC voltage or current units to be reported.
7. If making an AC lock-in measurement, select the *SELECT REFERENCE* menu option and select the reference source to be used.
8. Press **ESC** to exit the menu options.

AC LOCK-IN MODE

AC Lock-in amplification allows accurate measurements to be made in the presence of large amounts of noise. By providing a reference signal of the same frequency as the signal to be measured, a lock-in amplifier can synchronize itself to the signal to reject the components of the signal that are not of the same frequency.

The OL 730D accomplishes this by using its DSP to generate a high quality sine wave and multiply it by the incoming signal to be measured. The product is then fed through a DSP low-pass filter of adjustable response time to achieve a stable RMS value of the incoming signal minus noise.

REFERENCE

The *REFERENCE* menu option provides three sources for the reference signal:

1. Internal Reference

When the internal reference option is selected, the DSP generates the reference frequency from its own clock. To use this type of reference in a measurement, the reference signal must be supplied by the OL 730D, and connected to the external sensors or devices.

These external sensors or devices must then use the OL 730D's reference frequency to excite a sensor directly or synchronize a modulating device to it in order to produce a signal that is modulated at the reference frequency.

The TTL REF OUTPUT provides a TTL-level square wave reference in all reference modes (INTERNAL, EXTERNAL, or CHOPPER), that can be used in this manner.

The CH1 OUTPUT and CH2 OUTPUT can be used as sinusoidal reference sources by assigning them to be SIN or COS wave outputs in the SELECT CH1 OUTPUT and SELECT CH2 OUTPUT menu options.

2. Chopper Reference

When the chopper reference option is selected, a built-in chopper controller drives an optional optical chopper mechanism to the commanded frequency.

(With the appropriate hardware, the chopper controller can also be adapted to drive other frequency-producing devices such as oscillators, etc..)

The pins of the CHOPPER INTERFACE connector are assigned as follows:

Pin #	Description
1	150 Ω to +5 V (for opto-coupler drive)
2	TTL-level option input with 4.7 k Ω pull-up
3	150 Ω to +5 V (for opto-coupler drive)
4	TTL-level frequency input with 4.7 k Ω pull-up
5	Motor Drive 0 V to 12 V
6	Digital Ground
7	Digital Ground
8	Digital Ground
9	Motor Return

Figure 3 - OL 730D Programmable DSP Radiometer with OL 730D-CH Variable Speed Chopper

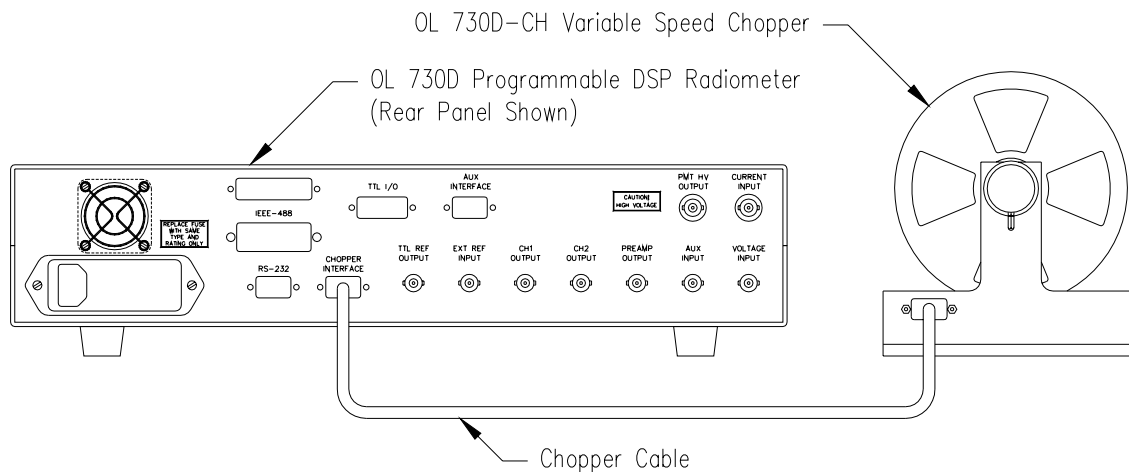

AC LOCK-IN MODE

3. External Reference

When the external reference option is selected, the DSP is synchronized to the square or sin wave signal applied to the EXT REF INPUT connector.

Note:

The EXT REF INPUT and CHOPPER CONTROLLER connectors should not be connected at the same time. Doing so may prevent the reference from being properly detected.

DYNAMIC RESERVE

When the signal-to-noise ratio of an AC signal is very low, most of the magnitude of the incoming signal is rejected by the lock-in process. The measured result is very small compared to the overall dynamic range of the preamplifier.

In order to display the signal with adequate resolution it must be re-amplified after the lock-in process. This allows the resolution of the display to be increased without increasing the gain of the preamplifier.

The *SET DYNAMIC RESERVE* menu option determines the amount of amplification that is applied after the lock-in process in 20 dB (X10) steps.

AC/DC COUPLING

When a signal contains a large DC offset, AC coupling can be used to block the DC portion of the signal. Doing this allows the preamplifier to be set to a more sensitive gain range, thereby allowing better dynamic range.

Select AC or DC coupling in the *SELECT INPUT SOURCE* menu option.

MEASUREMENT TYPE

The lock-in process produces a result that is the RMS value of the fundamental frequency of the signal at the reference frequency.

In order to correlate these values to other physical quantities, it is sometimes desirable to convert the reading to other units of voltage or current.

The *SELECT MEASUREMENT* menu option allows the user to select the type of voltage or current units to be displayed.

Units	Conversion Factor
SIN RMS	1.0000000
SIN PEAK	1.4142136 (02)
SIN PK-PK	2.8284271 (202)
SQU RMS	1.1107207 (π / 202)
SQU PEAK	1.1107207 (π / 202)
SQU PK-PK	2.2214415 (π / 02)

These conversion factors are exact only when the incoming signal (excluding noise) is a perfect sinusoidal or square wave signal.

NOTCH FILTERS

The notch filters are capable of removing large quantities of line noise interference from the signal.

The 1X filter is adjusted at the factory to 50 Hz or 60 Hz, and the 2X filter is adjusted for 100 Hz or 120 Hz, depending on the line frequency of the country to which the OL 730D is shipped.

Using the notch filters when line noise is a problem allows more sensitive gain settings to be used without causing an overload condition, thereby allowing better overall performance of the OL 730D.

However, the notch filters also attenuate signal frequencies that are near the notch frequencies ($Q=4$), and should not be used when the reference frequency is near the notch frequency.

The effect of the notch filters can be observed by using an oscilloscope to monitor the voltage at the PREAMP OUTPUT BNC connector on the rear panel of the OL 730D.

It is recommended to only use the notch filters when it can be determined that line noise interference is causing an undesirable overload condition, and when using a reference frequency that is far enough away from the notch frequency to avoid unacceptable attenuation of the signal of interest.

DC MODE

The DC mode allows measurement of the DC (frequency=0) component of a signal.

To enable DC measurement of a current or voltage signal, select the DC current or voltage option from the *SELECT INPUT SOURCE* menu option.

PHOTON COUNTING MODE

The photon counting mode allows measurement of the frequency of the signal applied to the AUX INTERFACE connector.

The AUX INTERFACE connector receives signal from, and supplies power to the optional photon counter discriminator.

To enable photon counting, power down the OL 730D and connect the discriminator to the AUX INTERFACE connector. If using the optional PMT HV supply of the OL 730D to bias a PMT detector, connect this also while the OL 730D power is off. (See the *OL 730D-HV PMT HIGH VOLTAGE SUPPLY* section.)

Turn on the OL 730D power and select the photon counter from the *SELECT INPUT SOURCE* menu option.

The pins of the AUX INTERFACE connector are assigned as follows:

Pin #	Description
1	+5 V
2	+5 V
3	TTL-level overload input
4	-5 V
5	-5 V
6	TTL-level pulse input
7	Analog Ground
8	Analog Ground
9	Analog Ground

TTL INPUT/OUTPUT

TTL INPUT/OUTPUT

The TTL I/O connector on the rear panel of the OL 730D provides the user with general-purpose, TTL-level inputs and outputs which can be set, cleared, and read via the computer interface(s).

This feature enables automation and/or monitoring of external events and/or devices using the OL 730D as the interface to the computer.

The TTL I/O connector provides eight TTL outputs, and two TTL inputs. The TTL inputs also function as triggers which can be software-configured to trigger the OL 730D to transmit the present reading or store it for later transmission.

The pins of the TTL I/O connector are assigned as follows:

Figure 4 - OL 730D TTL I/O Connector

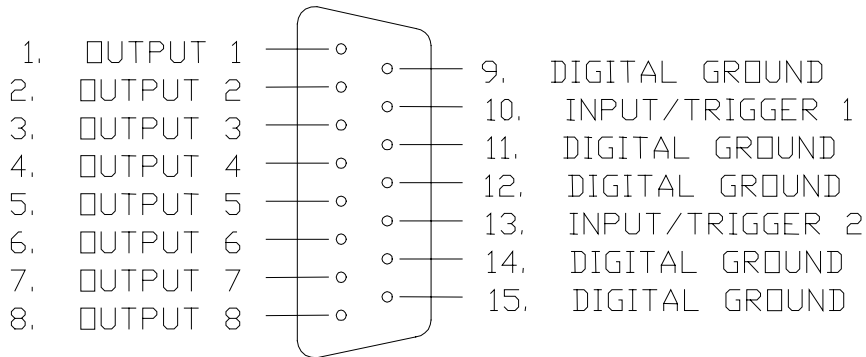

P001170

DETECTOR SETUP LIBRARY

Once a detection system has been calibrated, a measurement can be displayed in any corresponding user selectable units. The OL 730D is capable of displaying signals in those units directly, as well as sending them over the computer interface(s). In order to do this, the OL 730D must be programmed by the user with a calibration factor with which it can convert amperes or volts into the desired units.

The OL 730D can hold up to 25 different detector setups with its corresponding units (up to 20 characters) and descriptive text (up to 37 characters). Refer to Appendix C for a listing of the factory preset Detector Setups. This Detector Setup Library will be undefined if no calibrated detector/filter/input optic combinations were supplied with the OL 730D.

To program a detector setup into the OL 730D:

1. The DET key is pressed and the ENTER key is used to select the desired detector setup location. "DETECTOR NOT DEFINED" indicates the location is empty. Press the ENTER key to select the desired detector setup.
2. Check the following *MENU* options and configure as desired:
 3. SELECT INPUT SOURCE
 4. SELECT MEASUREMENT
 5. SELECT REFERENCE
 6. SELECT DYNAMIC RESERVE
 7. SELECT NOTCH FILTERS
 12. SELECT UPDATE RATE
 17. SET PMT HIGH VOLTAGE
 18. SET PMT FLUX LIMIT
3. For operation with a photomultiplier, the desired voltage level of the PMT high voltage supply must be set using the *SET PMT HIGH VOLTAGE* menu option.

Note:

This step is not necessary if the desired voltage level is already set or if the PMT supply is not installed.

4. The MENU key is then pressed and the ENTER key is used to select the EDIT DETECTOR menu option. Once in the EDIT DETECTOR option:
 - A. The description to be displayed when selecting a detector using the DET key is edited. In this mode:

The up and down arrow keys change the character at the blinking cursor. The characters available are: upper/lower case characters, numbers, punctuation and mathematical symbols. They are displayed in the following order:

[space] A - Z a - z 0 - 9 ; : < = > ? @ ! " # \$ % & ' () * + , - . /

The up and down arrow keys can be used to scan forward and backward through this character set to reach the desired character. Pressing the right arrow key advances the cursor.

Pressing the ZERO key erases characters.

Pressing the ESC key goes to the next mode without storing the text changes.

Pressing the ENTER key stores the text changes and advances to the next mode.
 - B. The units to be displayed on the bottom line are edited. The units are entered in the same manner as the description (see above).

DETECTOR SETUP LIBRARY

C. The calibration factor in amperes/optical unit is edited. In this mode:

The ENTER key changes the number or sign at the blinking cursor. No other characters can be entered when entering the calibration factor.

Pressing the right arrow key advances the cursor.

Pressing the ESC key proceeds to the next mode without storing the calibration factor changes.

Pressing the ENTER key stores the text and then proceeds to the next mode.

EXAMPLE:

CAL 1.581 E-10 AMPS/ Footlamberts
--

This indicates that Footlamberts = amperes /1.581 E-10.

The calibration factor is used to calculate the corresponding optical quantity as follows:

$$O = S / K$$

where: O = optical quantity (ex. footlamberts)
S = signal (amperes)
K = calibration factor (ex. 1.581 E-10 amperes/footlambert)

D. The input source is displayed for verification and can be changed if necessary.

E. If the high voltage supply is installed, its setting is displayed for verification and can be changed if necessary.

5. After the detector setup has been defined, the UNIT key may be used to select the user-defined units.

MEMORY HOLD MODES

The MEM key activates the two memory hold modes: STORE and RECALL. Successive presses of this key rotates the display through the STORE, RECALL and normal operating modes. There are 99 memory registers (storage locations) available for saving a reading and its corresponding units.

Note:

The contents of the 99 memory registers are automatically cleared when the OL 730D is powered up.

STORE

On the first press of the MEM key, the OL 730D is in the STORE mode and "Sxx" will be displayed in the top, left corner of the display. ("xx" indicates the current memory location to be used.)

When in this mode, pressing the ENTER key will store the displayed reading along with its corresponding units into the displayed memory location. The display will then increment to the next memory location.

The up and down arrow keys will scroll through the memory locations.

RECALL

On the second press of the MEM key, the OL 730D is in the RECALL mode and "Rxx" will be displayed along with the stored reading and its corresponding units. ("xx" indicates the currently displayed memory location.) If nothing is stored in this memory location, the rest of the display will be blank.

When in this mode, the left and right arrow keys scroll through the memory locations, displaying their contents.

Pressing the ZERO key will erase the displayed memory location contents. To erase the contents in all the locations, the CLEAR MEM (1-99) menu option can be used.

EXIT FROM MEMORY HOLD

A third press of the MEM key will exit from the memory hold mode. The MEM key must be pressed again to re-enter the STORE mode.

% OR DB UNITS

% or DB UNITS

In order for the OL 730D to read correctly in relative units (% or dB), the reading must first be normalized to a signal value. When the OL 730D powers up, the 100% and 0 dB values are normalized to a default value of 1 ampere.

The procedure for normalizing to the desired level is as follows:

1. The offset is nulled with the **ZERO** key.
2. The reference light source is applied to the detector.
3. The *NORMALIZE % VALUE* menu option is selected to accept that signal value as the new 100% or the *NORMALIZE dB VALUE* menu option is selected to accept that signal value as the 0 dB value.

The signal is now normalized and will continue to readout relative to the reference signal whenever those same units are selected until power-down.

When the units are dB and the signal is less than or equal to zero, "□□□□□□□□" will be displayed. This is because the logarithm of zero or of a negative number cannot be calculated.

Note:

For percentage measurement applications in which the reference signal is always the same, it may be convenient to devote one of the 25 detector library setups to that application, and make the calibration factor equal to the reference signal (in amperes) divided by 100. Ensure the proper unit is assigned to the calibration factor.

OL 730D-HV PMT HIGH VOLTAGE SUPPLY

The optional OL 730D-HV PMT High Voltage Supply allows operation of photomultiplier tubes at user programmable bias levels from 200 to 1100 volts. The voltage level can be set independently or can be programmed as part of a detector setup.

SETTING THE PMT VOLTAGE

To set the PMT voltage, press the MENU key and press the up or down arrow keys to the "SET PMT HIGH VOLTAGE" option. If the high voltage supply is not installed, "HIGH VOLTAGE SUPPLY NOT INSTALLED" will be displayed for 3 seconds before the display returns to the main menu. If the high voltage supply is installed, the current voltage level will be displayed. Pressing the up or down arrow keys adjusts the voltage level. Pressing the ENTER key stores the value and returns the display to the main menu.

The voltage value selected will be overridden when selecting a new detector and upon power-down by the value stored in the currently selected detector setup. To store the voltage value as part of a detector setup, use the EDIT DETECTOR menu option as described in the *DETECTOR SETUP LIBRARY* section.

*** WARNING ***

Even when set to "MIN", the HV output is approximately -165 volts !! Turn the power off before connecting or disconnecting the HV supply !!

SETTING THE PMT FLUX LIMIT

This menu option enables adjustment of the maximum PMT flux output limit. When the PMT supply is set to a value other than "MIN" and the current at the BNC input exceeds the PMT flux limit, the OL 730D will automatically shut down the high voltage supply in order to prevent damage to the PMT. After steps have been taken to reduce the incident light on the PMT, pressing any key will bring the supply back up to the specified voltage.

To set the PMT flux limit, press the MENU key and press the up or down arrow keys to the SET PMT FLUX LIMIT option. If the high voltage supply is not installed, "HIGH VOLTAGE SUPPLY NOT INSTALLED" will be displayed for 3 seconds before the display returns to the main menu. If the high voltage supply is installed, the current PMT flux limit will be displayed. Pressing the up or down arrow keys adjusts the level from 1.0 to 100.0 microamperes. Pressing the ENTER key stores the value and returns the display to the main menu. The PMT flux limit value is held in non-volatile memory and will hold its value after power-down.

TRIGGER DATA MODE

TRIGGER DATA MODE

The trigger inputs on the TTL I/O connector allow the most recent reading to be recorded in response to external TTL level transitions.

The recorded data is stored in the OL 730D's memory and will be lost on power-down. It can be retrieved from the OL 730D via RS-232 or GPIB.

The procedure for using the Trigger Data Mode is as follows:

1. Set the manual gain range on which the readings will be taken by using the G command or via the front panel. (Exponents are not recorded.)
2. Set the number of points to be recorded (1 to 2000), using the P command.
3. Arm the desired trigger using the A command. The trigger will then be armed and the selected TTL level transitions will cause the OL 730D to record readings until the buffer is full, at which time the trigger(s) will be automatically disarmed.
4. Retrieve the data from the Trigger Data Buffer using the B command. The data is transmitted to the host in binary, least significant byte first format. Each data point is a two byte integer representing the number of counts on the display. To convert a point to the mantissa of the reading, it must be divided by 10,000. The Trigger Data Buffer contents may be retrieved at any time, even if the triggers are still armed.

DC STORAGE MODE

The DC Storage Mode allows successive readings of current or voltage to be recorded in DSP memory for later download via RS-232 or GPIB to a host computer. The downloaded data can be imported into spreadsheet programs, etc. so that the data can be processed, logged, and/or visualized in a graph of signal value vs. time. The storage process can be initiated by a TTL trigger or by a command from the host computer.

When in DC Storage Mode, the OL 730D display will show the average value of the DSP memory buffer contents.

The DC Storage Mode readings are stored directly in DSP memory and can have time resolution of 1-255 samples. Since the sampling period is 10 μ s, this yields 10 μ s to 2.55 ms per reading. The number of readings stored can be set from 256-32768. The length in time of the stored data is calculated as follows:

$$\text{Storage Time} = (\# \text{ readings}) * (\# \text{ samples/reading}) * (10 \mu\text{s/sample})$$

The procedure for using DC Storage Mode is as follows:

1. Select the DC Storage Mode by using the I command or via the front panel menu option SELECT INPUT SOURCE.
2. Set the manual gain range on which the readings will be taken by using the G command or via the front panel GAIN key. (Exponents are not recorded).
3. Set the number of points to be recorded (256 to 32768), and the number of 10 μ s samples to be averaged into each point (1 to 255), using the P command.
4. Arm the desired trigger using the A command.
5. Trigger the selected trigger.
6. Retrieve the data from the OL 730D using the B command. The data is transmitted to the host in binary, least significant byte first format. Each data point as a two byte integer representing the mantissa of the reading/10,000. To convert a point to the mantissa of the reading, it must be divided by 10,000. The exponent of the readings is transmitted only once at the beginning of the B command's response.

TRISTIMULUS MODE

This option enables the OL 730D to measure CIE 1931 chromaticity coordinates (x, y and z) of continuous sources when used with: the OL 730-5A or OL 730-5H detector; the OL 730-5-T Tristimulus Filter Set; and with the appropriate input optics.

Note:

Some photometric measurement applications do not require any input optics.

The OL 730D performs the chromaticity coordinate measurement by prompting the user to measure the unknown continuous source with each of the four tristimulus filters (X1, X2, Y and Z) in succession. The chromaticity coordinates x, y and z are then calculated and displayed using the formulae:

$$x = \frac{X1 + X2}{X1 + X2 + Y + Z}$$

$$y = \frac{Y}{X1 + X2 + Y + Z}$$

$$z = \frac{Z}{X1 + X2 + Y + Z}$$

See *MEASURING CIE 1931 CHROMATICITY COORDINATES* for detailed information on performing the measurement.

TRISTIMULUS MODE

If the Tristimulus Filters are installed on the filter wheel of the OL 600 Direct Viewing Imaging Optics Module, the appropriate filter can be selected by turning the filter wheel control knob to the appropriate position. Most other types of measurements will require direct insertion of the appropriate tristimulus filter in the detector housing (see Figure 5).

Note:

Filter colorimeters are useful for measuring incandescent or continuous type light sources. It is recommended that measurements on emission or filtered sources be made with a spectroradiometer.

Figure 5 - Opto-Mechanical Layout of the OL 730-5A Silicon Detector

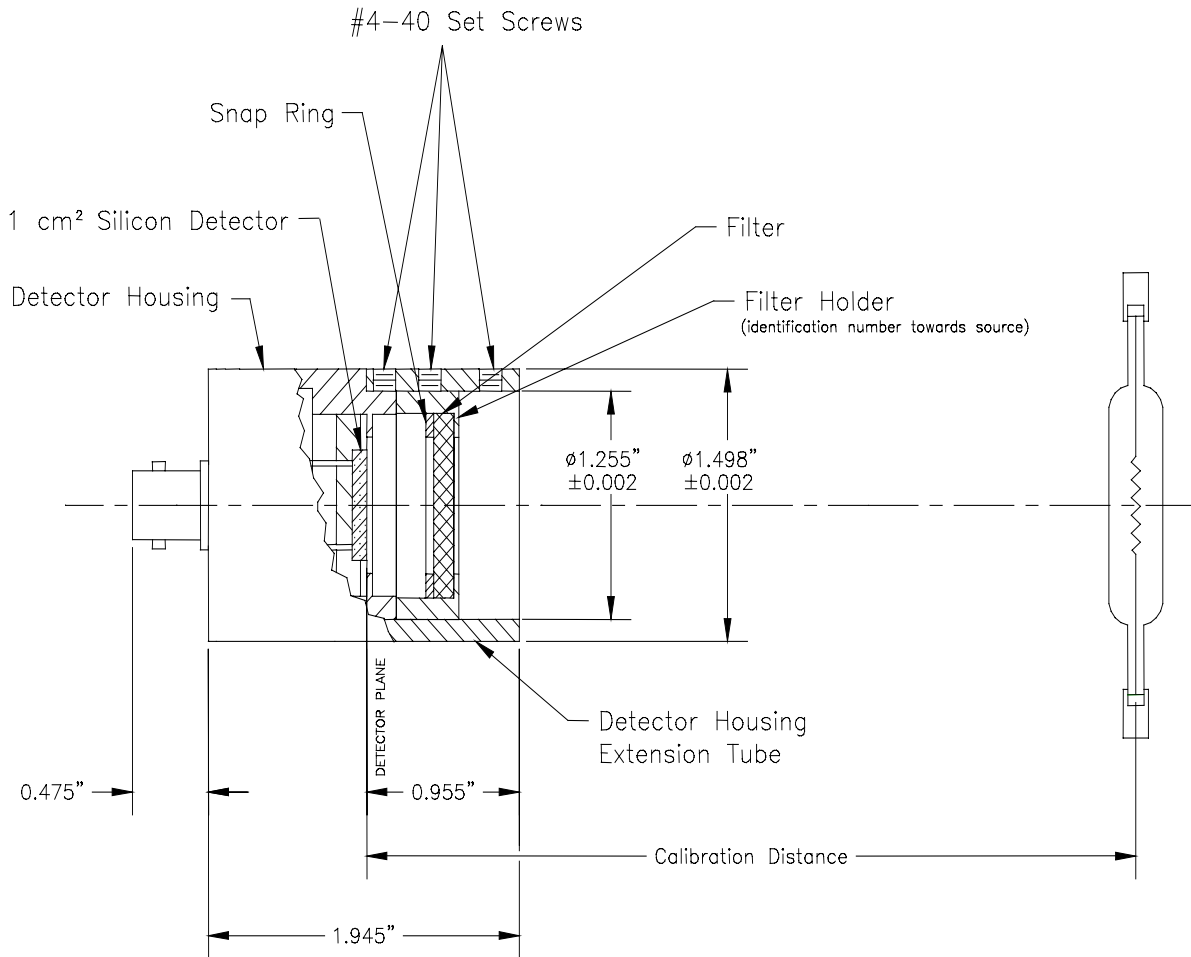

P000036A

MEASURING CIE 1931 CHROMATICITY COORDINATES

After selecting the TRISTIMULUS MODE option:

1. The user will be prompted to insert the X1 filter. Press the ENTER key.
2. The reading will be displayed in the presently selected units (amperes, volts, or counts). After the reading has settled, press the ENTER key.
3. Repeat steps 1 and 2 for the X2, Y and Z filters.

After the Z reading has been taken, the x, y and z chromaticity coordinates will be displayed.

The OL 730D must be calibrated for each of the four detector/tristimulus filter/input optic combinations with which it will be used. This can be accomplished using a spectrally calibrated light source with known tristimulus values X, Y and Z. The calibration factors obtained using the procedure described below must be stored in the OL 730D so that it can correctly calculate the chromaticity coordinates x, y and z of unknown continuous sources.

1. The standard source must be calibrated for the appropriate spectral output over the visible spectrum (380 nm to 780 nm). Since the X value consists of two components, X1 and X2, four "tristimulus" values X1, X2, Y and Z must be computed for the source from a knowledge of the source spectral output and the CIE 1931 spectral tristimulus values, $\bar{x}(\lambda)$, $\bar{y}(\lambda)$ and $\bar{z}(\lambda)$. (See Appendix E.)
2. The standard source is then used to calibrate the OL 730D with all four filters (and the appropriate input optics) in succession. The detector signal values X1u, X2u, Yu and Zu must be recorded.
3. The calibration factors for the X1, X2, Z filters are calculated by the following method:

$$CF_{X1} = \frac{X1 / X1u}{Y / Yu}$$

$$CF_{X2} = \frac{X2 / X2u}{Y / Yu}$$

$$CF_Z = \frac{Z / Zu}{Y / Yu}$$

Note: $CF_Y = 1$

These calibration factors can then be stored in the OL 730D using the *CAL TRISTIMULUS* menu option.

ENTERING CALIBRATION FACTORS

To enter the calibration factors for the Tristimulus Mode, select the CAL. TRISTIMULUS option from the menu. After selecting this option, the user is prompted to enter the calibration factor for the X1 filter. In this mode:

The up or down arrow keys change the number or sign at the blinking cursor.

Pressing the right arrow key advances the cursor.

Pressing the ESC key advances to the next calibration factor without storing the calibration factor changes.

Pressing the ENTER key stores the calibration factor changes.

The process is repeated for the X2 and Z filters.

Note:

The calibration factor for the Y filter is always 1 and is preset at the factory.

RS-232C / GPIB INTERFACE

The OL 730D is supplied with an RS-232C serial interface as a standard feature. An additional GPIB (IEEE-488) interface is also available as an option. The commands for these interfaces are the same.

COMMAND SET

l _____

Requests the OL 730D to return the currently displayed value in the corresponding units.

c _____

Requests the OL 730D to return the currently measured signal current in amperes, regardless of the displayed units.

D _____

Zeroes the dark current.

U X _____

This command, followed by a space and an integer number from 0 to 3, selects the displayed units;

where	0	=	amperes
	1	=	user-defined units
	2	=	%
	3	=	dB

G XXX _____

This command followed by a space and an integer number from 3 to 10 (3 to 11 for HSD), will set the gain range. A value of 0 will select auto-ranging.

F XXXXX _____

This command followed by a space and a number from 10 to 10000, sets the commanded reference frequency. The commanded reference frequency is used when the OL 730D is in AC mode, with an external or chopper reference mode selected.

The OL 730D will return the present measured reference frequency, which in the case of the chopper reference, may not immediately match the commanded frequency.

f _____

Requests the OL 730D to return the measured value of the reference frequency.

T XX _____

This command followed by a space and a 2 digit hexadecimal number sets the values of the TTL outputs.

The OL 730D will return the value of the TTL outputs, followed by two integers (0 or 1) representing states of the Trigger 1 and Trigger 2 inputs.

O X X

This command followed by a space and an integer (1 or 2) representing the CH1 or CH2 output, another space and another integer (0 to 8) representing a source selection, sets the source of the voltage on the CH1 or CH2 OUTPUT BNC connector on the rear panel.

The possible output sources are:

- 0 SIN Wave Reference
- 1 COS Wave Reference
- 2 x Signal Component
- 3 y Signal Component
- 4 X Signal Component
- 5 Y Signal Component
- 6 Resultant Magnitude (AC mode) or Average Signal (DC mode)
- 7 Raw Signal Input
- 8 Average AUX Input

See the *SELECT CHI OUTPUT* menu option.

H X

This command followed by a space and an integer from 0 to 2 selects the reference source to be used in an AC measurement.

The possible reference sources are:

- 0 Chopper reference
- 1 Internal reference
- 2 External reference

See the *SELECT REFERENCE* menu option.

I X

This command followed by a space and an integer from 0 to 6 selects the input source to be measured.

The possible input sources are:

- 0 AC current, AC coupling
- 1 AC current, DC coupling
- 2 DC current, DC coupling
- 3 AC voltage, AC coupling
- 4 AC voltage, DC coupling
- 5 DC voltage, DC coupling
- 6 Photon counter
- 7 DC current storage
- 8 DC voltage storage

See the *SELECT INPUT SOURCE* menu option.

K XX

This command followed by a space and an integer multiple of 20 from 0 to 80, selects the dynamic reserve to be used in an AC measurement.

See the *SELECT DYNAMIC RESERVE* menu option.

Q X _____

This command followed by a space and an integer from 0 to 3 selects the the state of the notch filters.

The possible states are:

- 0 Both notch filters inactive
- 1 1X notch filter active
- 2 2X notch filter active
- 3 Both notch filters active

See the *SELECT NOTCH FILTERS* menu option.

Z _____

This command causes all communication processes, buffers, etc. to be reset to their initial, power-on state.

N _____

Normalizes the reading to 100% if the currently selected units are %, or to 0 dB if the units are dB.

V XXXXX _____

This command followed by a space and an integer number from 200 to 1100 will set the PMT supply voltage, if installed. The value is rounded to the nearest 5 volts. A number less than 200 will set the PMT supply voltage to it's minimum value (about 165 volts).

E _____

Has the same effect as pressing the ENTER key on front panel. It is used in automatic factory calibration procedures and integration mode.

S XX _____

This command followed by a space and an integer number from 1 to 25 selects a detector from the detector setup library.

R XXX XX.X _____

This command followed by a space and an integer number from 3 to 10 for current or 0 to -3 for voltage representing a gain range, and a number from 0.0033 to 4096.0 (see menu option 2. *SET RESPONSE TIME*) representing a response time, will set the response time for that gain range.

M XX _____

This command followed by a space and an integer number from 1 to 99 will request the OL 730D to send the contents of that memory hold location.

X XX XX X

This command allows downloading of detector setup information from the host computer to the OL 730D.

In all cases, it must be followed by a space and an integer number from 1 to 25 indicating the detector number, another space and then an integer number (0-91) identifying the type of data being sent (see table below). The last number may be a character, integer or floating point number, depending on the identity of the data being sent.

Detector Setup Information Data Type		
Number	Format	Data Identity
0 - 37	Character	Detector Description Text (20h-7Fh)
40 - 59	Character	Units Description Text (20h-7Fh)
60	Integer	PMT Voltage (0-1100)
61	Character	Input Type (0=AC CURRENT, AC CPLG) (1=AC CURRENT, DC CPLG) (2=DC CURRENT, DC CPLG) (3=AC VOLTAGE, AC CPLG) (4=AC VOLTAGE, DC CPLG) (5=DC VOLTAGE, DC CPLG) (6=PHOTON COUNTER) (7=DC CURRENT STORAGE) (8=DC VOLTAGE STORAGE)
70	Floating Point	Calibration Factor (9.999 E99)
80	Integer	PMT Flux Limit ((10-1000) E-7 Ampere)
90	String	Detector Description Text The entire detector description delimited by “ ” characters.
91	String	Units Description Text The entire units description delimited by “ ” characters.

Y XX XX

This command requests uploading of detector setup information from the OL 730D to the host computer.

This command must be followed by a space and an integer number from 1 to 25 indicating the detector number, another space and then an integer number (0-91) identifying the type of data being sent (see table above).

The OL 730D will respond by returning the command as sent, followed by the requested data in the format shown in the above table.

@

Requests the OL 730D to return the values of the last tristimulus measurement. If no tristimulus measurement has been performed since power-on, x, y and z will equal zero.

P XXXX or P XXXX XXX _____

When not in DC Storage Mode (P XXXX):

This command followed by a space and an integer number from 1 to 2000, sets the number of readings to be stored in the trigger data buffer.

When in DC Storage Mode (P XXXX XXX):

This command followed by a space and an integer number from 256 to 32768, another space and an integer number from 1 to 255, sets the number of readings to be stored in the DC Storage data buffer and the number of 10 μ s samples that will be averaged into each reading.

The OL 730D will respond by sending the command as sent, plus a status byte that indicates the state of the DC Storage Mode as follows:

- b0 = Ready for trigger
- b1 = Triggered
- b2 = Ready for download
- b3 = Download in progress
- b4-7 = *reserved*

p _____

Requests the OL 730D to return the size of the buffer and if in DC Storage Mode, the number of samples per entry and the DC Storage Mode status as described above.

J _____

This command causes the latest reading to be stored in the first location of the trigger data buffer.

A X X _____

This command followed by a space and an integer representing the trigger number(1 or 2), another space and integer representing the edge(s) to trigger on, arms the trigger data buffering mode.

Edge Code	Edge
0	None (disarm trigger)
1	Falling edge
2	Rising edge
3	Both edges (rising or falling)

B _____

This command request a binary dump of the trigger buffer or storage buffer contents. The response to this command will be a B followed by an integer representing the exponent of the data in the trigger buffer, another integer representing the data type (0=integer), and another integer representing the number of bytes to be received by the host. The readings in the trigger buffer or the DC Storage Mode are always in amperes regardless of the units selected on the OL 730D.

Immediately following this response, the OL 730D will be ready to send the binary data to the host.

X _____

This command, followed by a space and an integer from 0 to 3, controls the state of the integration mode.

Where:

- 1 = Advance the integration mode through the sequence of CLR, RUN, HLD.
- 0 = Place the integration mode in the CLR state.
- 1 = Place the integration mode in the RUN state.
- 2 = Place the integration mode in the HLD state.
- 3 = Turn the integration mode off.

\$

Requests the OL 730D to return the current state of the integration mode.

Where:

-1	=	The integration mode is off.
0	=	The integration mode is in the CLR state.
1	=	The integration mode is in the RUN state.
2	=	The integration mode is in the HLD state.

% X

This command, followed by a space and an integer number from 0 to 5, will select the type of displayed units of AC measurement.

The possible displayed units are:

0	=	SIN RMS
1	=	SIN PEAK
2	=	SIN PK-PK
3	=	SQU RMS
4	=	SQU PEAK
5	=	SQU PK-PK

SYSTEM STATUS BYTE

For every command, a system status byte is returned to the host as the last two bytes of the message. The system status byte is constructed as follows:

bit 7	Busy flag (The OL 730D is performing some menu function)
bit 6	Integration mode
bit 5:4	Currently selected units (00=SI, 01=user-defined, 10=%, 11=dB)
bit 3	<i>reserved</i>
bit 2	Memory hold mode
bit 1	Overrange
bit 0	Unlock

COMMUNICATION PROTOCOL

COMMUNICATION PROTOCOL

RS-232C

The communication protocol is an interactive protocol that requires both controller and device to be satisfied with the communication transaction that occurred. The protocol requires a HOST controller (computer) and one or more devices (OL 730D).

Note:

A sample remote control program is supplied with the OL 730D (See Appendix A)

All transactions must be initiated by the HOST. The HOST begins a transaction by transmitting an EOT (0xFF) onto the communications interface. This signals the devices that a transaction is pending and to prepare for it. The next byte transmitted is a DEVICE address.

Note:

No device address should be duplicated on the communications interface.

The address is a 7 bit address (0x00 - 0x7E) which provides two functions for the DEVICE and the HOST. The address can be used to signal the DEVICE that the host plans to transmit data to the DEVICE or the HOST can set BIT 7 of the address high to ask the DEVICE if it has any messages to transmit to the HOST. Two transaction types are supported: HOST sends data to the DEVICE and HOST receives data from the DEVICE. All data is seven bit ASCII.

EOT	=	0xff
ACK	=	0x06
NAK	=	0x15
STX	=	0x02
ETX	=	0x03
CHK	=	A 7 bit accumulative checksum.
ADD	=	DEVICE ADDRESS

The following respective events must occur to complete a successful transaction:

HOST sends data to the DEVICE:

<u>Host sends</u>	<u>Device responds</u>
EOT ADD	ACK (If DEVICE can receive data). NAK (If DEVICE can not receive data).
STX message ETX CHK	ACK (If checksum matches). NAK (If checksum fails).
Transfer is complete.	

HOST receives data from the DEVICE:

<u>Host sends</u>	<u>Device responds</u>
EOT ADDB7	ACK (If device has data to send). NAK (If device has nothing to send).
ACK (If checksum matches) NAK (If not) Transfer is complete.	STX message ETX CHK

HOST receives binary data from the DEVICE:

<u>Host sends</u>	<u>Device responds</u>
EOT ADDB6	ACK (If device has data to send). NAK (If device has nothing to send).
ACK (If checksum matches) NAK (If not) Transfer is complete.	STX message ETX CHK

RS-232C Connector Pinout

On the rear panel of the OL 730D is a male, 9-pin, D-subminiature connector which can be connected to a PC serial port using a standard RS-232C cable. The pinout is as follows:

Pin 2:	Rx	Receive Data
Pin 3:	Tx	Transmit Data
Pin 5:	Gnd	Signal Ground

COMMUNICATION PROTOCOL

GPIB

The GPIB interface is supported in a similar fashion as the serial interface, except, checksums are not used and all of ACK/NAK handshaking is handled by the GPIB interface card. The messages must be packaged between STX and ETX and must be terminated with an EOI asserted. Please note that the checksums must not be used.

The OL 730D will request service each time an event has occurred which would change the state of the serial poll byte. The GPIB controller should check for SRQ from the OL 730D and should constantly monitor the value provided by the SPOLL function. The OL 730D uses the SPOLL value as follows:

- Bit 0 - Active High, implies a message is available in the outgoing buffer.
- Bit 1 - Active High, implies the controller is busy.
- Bit 2 - Active High, implies the controller input buffer is full. No additional messages should be sent until this bit is cleared.
- Bit 3 - Not used.
- Bit 4 - Not used.
- Bit 5 - Not used.
- Bit 6 - SRQ status. Defined by SPOLL command.
- Bit 7 - Not used.

VOLTAGE SELECTION

Figure 6 - OL 730D IPM Location

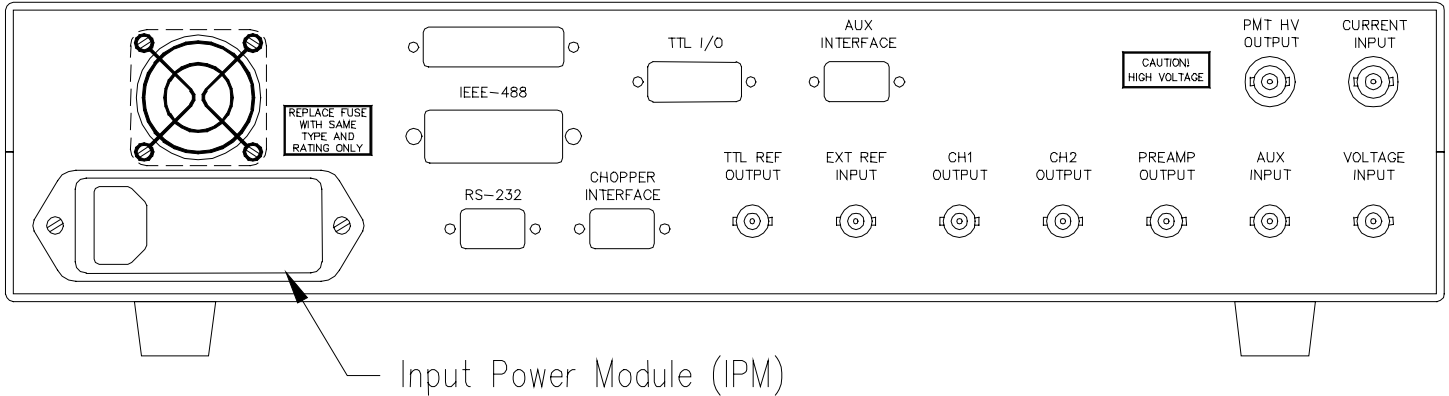

P000597A

The OL 730D can be configured to operate at one of two different AC line voltages; 115 or 230 volts AC (" 10%) at either 50 or 60 Hz. The OL 730D input power module (IPM) located on the rear of the OL 730D accepts a standard IEC power line connector. The IPM is used to configure the OL 730D for one of the two voltages. The white voltage indicator on the IPM shows the voltage currently selected.

Note:

The 120V setting is for an AC input of 115 volts and the 240V setting is for 230 volt operation. Each of the settings allows for " 10% variation in the AC supply line.

VOLTAGE SELECTION

The following procedure should be used to change the OL 730D voltage setting:

1. Pry off the plastic front cover of the IPM by inserting a small flat blade screwdriver or similar tool into the slot.
2. Use a small pair of pliers to remove the small PCB located inside. It is important to note the direction and orientation of the PCB so that it can be properly reinserted.
3. Slide the white plastic voltage indicator around the PCB until it is opposite of the desired voltage setting. The indicator should be seated in the notch on the side/edge of the PCB.

Figure 7 - OL 730D Input Power Module PCB

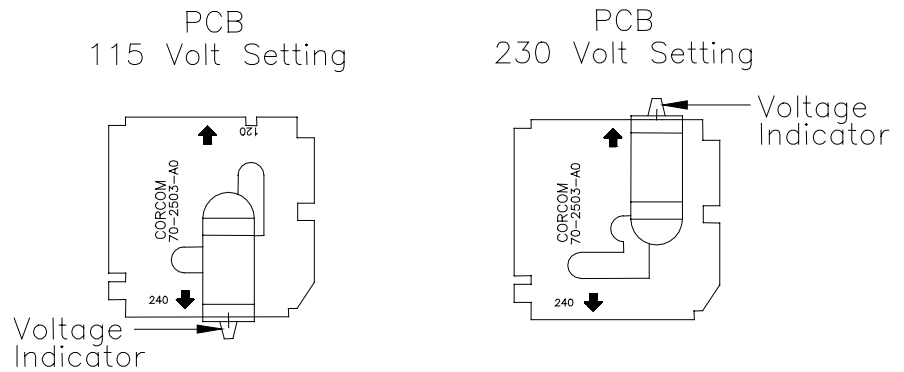

P001175

Note:

Once the indicator is seated properly in the notch, its pointer will align with the corresponding voltage label on the front cover.

4. Reinsert the PCB. A positive snap will indicate that the PCB is seated properly.
5. Align the front cover with the indicator and snap it back into place.
6. Plug the power cord into the IPM and test the OL 730D for proper operation

WARRANTY

Optronic Laboratories, Inc. warrants that all goods supplied will be of the kind described or in any specification and drawings approved by Optronic Laboratories, Inc. and will be free from defects in material and workmanship for one year from the date of purchase by the original Purchaser. During this period, Optronic Laboratories, Inc. will at its option either repair or replace any goods that are found to be defective in material or workmanship - provided the goods are returned to Optronic Laboratories, Inc. in Orlando, Florida, with all shipping, insurance and delivery charge prepaid. This Warranty does not extend to batteries, fuses, and glass phototubes (if any), or other items of limited durability, nor does this warranty cover damage to goods caused by leaky or otherwise defective batteries, by Purchaser use of improper batteries and by misuse or abuse, unauthorized alteration, excessive line voltage, excessive temperatures (above 160 degrees F), extreme environmental conditions (such as extremely dusty or wet environment), corrosive atmospheres or servicing by unauthorized personnel. The items returned shall only be accepted when accompanied by a written statement setting forth the nature and suspected cause of the alleged deficiencies. After the initial one year warranty, repairs performed by Optronic Laboratories, Inc. are covered under a limited ninety (90) day warranty. THERE ARE NO OTHER WARRANTIES, EXPRESS OR IMPLIED, (INCLUDING THE WARRANTY OF FITNESS FOR A PARTICULAR PURPOSE OR IMPLIED WARRANTY OF MERCHANTABILITY) OTHER THAN THE WARRANTY SET FORTH HEREIN

Table 1
Fundamental Radiometric Quantities
(The International System (SI) Unit)

Quantity	Symbol	Defining Equation	Units
Radiant Energy	Q, Q_e		J (Joule)
Radiant Energy Density	w, w_e	$w = dQ/dV$	Jm^{-3}
Radiant Power or Flux	M, M_e	$M = dQ/dt$	W (Watt)
Radiant Exitance	M, M_e	$M = dM/dA$	Wm^{-2}
Irradiance	E, E_e	$E = dM/dA$	Wm^{-2}
Radiant Intensity	I, I_e	$I = dM/dT$	Wsr^{-1}
Radiance	L, L_e	$L = d^2M/dT (dA \cos \theta)$ $= dI/dA \cos \theta$	$Wm^{-2}sr^{-1}$
Emissivity	g	$g = M/M_{bb}$	--

Table 2
Fundamental Photometric Quantities
(The International System (SI) Unit)

Quantity	Symbol	Defining Equation	Units
Luminous Energy	Q_v	$Q_v = K_m \int_0^4 V(\delta) Q_\delta d\delta$	lm s
Luminous Energy Density	w_v	$w_v = dQ_v/dV$	lm s m ⁻³
Luminous Flux	M_v	$M_v = dQ_v/dt$	lm
Luminous Exitance	M_{v_s}	$M_{v_s} = dM_v/dA$	lm m ⁻²
Illuminance	E_v	$E_v = dM_v/dA$	lm m ⁻²
Luminance Intensity	I_v	$I_v = dM_v/dT$	cd = lm sr ⁻¹
Luminance	L_v	$L_v = d^2_v \mathcal{L}dT (dA \cos \mathcal{L})$ $= dI_v/dA \cos \mathcal{L}$	cd = m ⁻²
Luminous Efficacy	K	$K = M_v/M$	lm W ⁻¹

Table 3**Luminance (Photometric Brightness) Conversion Factors**1 Nit = 1 Candela/m²1 Stilb = 1 Candela/cm²

1 Apostilb (International) = 0.1 millilambert = 1 blondel

1 Apostilb (German Hefner) = 0.09 millilambert

1 Lambert = 1000 millilamberts

Number of → Multiplied by ↓ Equals Number of	Footlambert	*Candela/m ²	Millilambert	Candela/in ²	Candela/ft ²	Stilb
Footlambert	1.	0.2919	0.929	452.	3.142	2919.
*Candela/m ² (Nit)	3.426	1.	3.183	1550.	10.76	10000.
Millilambert	1.076	0.3142	1.	487.	3.382	3142.
Candela/in ²	0.00221	0.000645	0.00205	1.	0.00694	6.45
Candela/ft ²	0.3183	0.0929	0.2957	144.	1.	929.
Stilb	0.00034	0.0001	0.00032	0.155	0.00108	1.

* The International System (SI) unit.

Table 4
Illumination Conversion Factors

1 Lumen = 1/683 lightwatt
 1 Lumen-hour = 60 lumen-minutes
 1 Footcandle = 1 lumen/ft²
 1 Watt-second = 1 joule = 10⁷ ergs
 1 Phot = 1 lumen/cm²
 1 Lux = 1 lumen/m²

Number of → Multiplied by ↓ Equals Number of	Footcandles	* Lux	Phots	Milliphots
Footcandles	1.	0.0929	929.	0.929
* Lux	10.76	1.	10000.	10.
Phot	0.00108	0.0001	1.	0.001
Milliphot	1.076	0.1	1000.	1.

* The International System (SI) unit.

APPENDIX A

SAMPLE REMOTE CONTROL PROGRAMS

Two executable remote control programs are provided to demonstrate how to control the OL 730D using a remote computer via the standard RS-232C or optional IEEE-488 (GPIB) interfaces. The corresponding "C" source code is also provided so that the user can write customized remote control programs.

730DR232.EXE	Executable program which communicates with the OL 730D via RS-232C. The program assumes that the interface cable between the OL 730D and the remote computer is installed on COM1 and the OL 730D device address is set to 1.
730DR232.C	C source code for the 730DR232.EXE program. The source code was compiled with Zortech C++, Ver. 3.0.
730DGPIB.EXE	Executable program which communicates with the OL 730D via GPIB. The program assumes that the OL 730D GPIB device address is set to 1.
730DGPIB.C	C source code for the 730DGPIB.EXE program. The source code was compiled with Zortech C++, Ver. 3.0.

Note:
 To use the IEEE-488 interface, a B&C MicroSystems PC488A with IO base address located at 0x22E1 and hardware configured to be a controller must be installed into the host computer.

The following menu is offered with either program:

=====Optronics Laboratories, Inc, 1996 ===== GPIB

- | | |
|---|---|
| <ul style="list-style-type: none"> 1) Reset 730D Communications 2) Read Luminance 3) Read Detector Current or Voltage 4) Zero Dark Current or Voltage 5) Select Units (0-3) 6) Set Gain Range (>0=auto) 7) Normalize Reading 8) Set PMT Voltage (-200 to -1100) 9) Select Detector (1 to 25) A) Set Resp. Time(0 to -10)(0.0033 to 4096) B) Select Input (0 to 6) C) Read Memory Hold Location (1 to 99) D) Remote Enter Key E) Read Frequency F) Set Frequency | <ul style="list-style-type: none"> G) Select Reference H) Set Notch Filters I) Select DAC Outputs J) Select Update Rate K) Set Dynamic Reserve L) Read Tristimulus M) Download from File N) Upload to File O) Set number of Points to buffer P) Trigger the photometer R) Arm External Trigger S) Upload Binary Buffer T) Set TTL I/O Q) Quit |
|---|---|

Enter your choice < >

Choosing an option from the menu will execute the appropriate remote command. Please refer to the remote command language for specific command details.

APPENDIX B

OPTIONAL ACCESSORIES

A large selection of optional accessories are available for use with the OL 730D Programmable DSP Radiometer which enables the unit to measure a multitude of photometric and radiometric parameters. These accessories consist of detectors, optical filters, input optic modules and calibration standards.

DETECTORS

A listing of the optional detectors available for use with the OL 730D along with their useful wavelength range and NEP (noise equivalent power) at the wavelength of peak response is given below:

<u>Model No:</u>	<u>Detector Type</u>	<u>Wavelength Range (nm)</u>	<u>NEP (watts)</u>
OL 730-5A	Silicon	200 to 1100	2×10^{-14} @ 960 nm
OL 730-5H	Silicon w/preamp	200 to 1100	2×10^{-15} @ 960 nm
OL 730-InGaAs	InGaAs (TE Cooled)	800 to 1800	1.5×10^{-13} @ 1580 nm
OL 740-15	PMT (S-20)	200 to 800	6×10^{-17} @ 430 nm
OL 730-Ge	Ge (TE Cooled)	800 to 1800	8×10^{-13} @ 1500 nm
OL 730-PbS	PbS (TE Cooled)	1000 to 3000	1.5×10^{-12} @ 2500 nm
OL 730-PbSe	PbSe (TE Cooled)	1000 to 6000	1.5×10^{-10} @ 4400 nm
OL 730-Si	Silicon (TE Cooled)	200 to 1100	2×10^{-15} @ 960 nm

OPTICAL FILTERS

A listing of the optical filters available for use with the OL 730D along with their functions are:

<u>Model No.</u>	<u>Designation</u>	<u>Function</u>
OL 730-5-PF	Photopic Filter	Modifies spectral response of silicon detector to CIE Y curve.
OL 730-5-LED	LED Photometric Filter	High accuracy CIE Y filter.
OL 730-5-RF	Radiometric Filter	Provides constant ($\pm 5\%$) response over the 460 nm to 980 nm wavelength range when used with silicon detector
OL 730-5-T	Tristimulus Filters (set of 4)	Modifies the spectral response of silicon detector to \bar{y} , \bar{x}_r , \bar{x}_z and \bar{z} functions.
OL 730-5-RB	Color Temperature Filters (set of 2)	Enables measurement of color temperature using red/blue ratio.
OL 730-5-XXX	Spectral Bandpass Filters	Consult factory.
OL 730-1	Attenuation Filter	10% (nominal) attenuation filter
OL 730-2	Attenuation Filter	1% (nominal) attenuation filter
OL 730-3	Attenuation Filter	0.1% (nominal) attenuation filter

INPUT OPTICS

The versatility and measurement capability of the OL 730D is greatly enhanced with the selection of optional input optic modules. With the proper input optics, the OL 730D can be calibrated and programmed to read directly in the desired optical unit. In addition, up to 25 different optical head configurations with their associated calibration factors can be stored in the OL 730D at any one time. In actual use, the optical filter (if required) is inserted in the selected detector head and the combination is attached to the input optic module. All of the detectors, filters and input optic modules are user interchangeable.

- OL 600 Direct Viewing Imaging Optics Module
- OL Series 85 Cosine Receptors (transmitting)
- OL IS□430 4□Inch Integrating Sphere Cosine Receptor (in□line ports)
- OL IS□440 4□Inch Integrating Sphere Cosine Receptor (90E ports)
- OL 15 LED Receptor
- OL 730□7G Glass Fiber Optic Probe
- OL 730□7Q Quartz Fiber Optic Probe

CALIBRATION STANDARDS

See Optronic Laboratories Condensed Catalog.

APPENDIX D
Certificate(s) of Calibration

APPENDIX E

TRISTIMULUS CALCULATIONS

The four detector/tristimulus filter/input optic combinations can be calibrated using a light source whose spectral output is known over the 380 to 780 nm wavelength range. A spectral radiance or irradiance standard can be used depending on which input optic is being used. A radiance standard is typically used when an imaging input optic such as the OL 600, OL 730-8, or OL 730-9 is being used. An irradiance standard is recommended when no input optics or a non-imaging input optic such as the OL Series 85 is being used.

The X1, X2, Y and Z spectral tristimulus values for sources are calculated using the CIE 1931 spectral tristimulus values $\bar{x}(\lambda)$, $\bar{y}(\lambda)$ and $\bar{z}(\lambda)$ as follows,

$$X1 = \int_{\lambda=380}^{504} E(\lambda) \bar{x}(\lambda) \Delta\lambda$$

$$X2 = \int_{\lambda=505}^{780} E(\lambda) \bar{x}(\lambda) \Delta\lambda$$

$$Y = \int_{\lambda=380}^{780} E(\lambda) \bar{y}(\lambda) \Delta\lambda$$

$$Z = \int_{\lambda=380}^{780} E(\lambda) \bar{z}(\lambda) \Delta\lambda$$

Where:

$E(\lambda)$	=	spectral values of the data file
$\bar{x}(\lambda)$, $\bar{y}(\lambda)$ and $\bar{z}(\lambda)$	=	CIE 1931 spectral tristimulus values
$\Delta\lambda$	=	wavelength interval of the data file [nm]

See this appendix for the values of $\bar{x}(\lambda)$, $\bar{y}(\lambda)$ and $\bar{z}(\lambda)$.

X-bar Spectral Tristimulus Values from 1931 CIE Standard Observer
(380 nm to 780 nm @ 1 nm intervals)

380.00 nm	1.368E-003 1.502E-003 1.642E-003 1.802E-003 1.996E-003	460.00 nm	2.908E-001 2.840E-001 2.767E-001 2.689E-001 2.604E-001	540.00 nm	2.904E-001 3.039E-001 3.176E-001 3.314E-001 3.455E-001	620.00 nm	8.545E-001 8.351E-001 8.149E-001 7.942E-001 7.730E-001	700.00 nm	1.136E-002 1.063E-002 9.939E-003 9.288E-003 8.679E-003
385.00 nm	2.236E-003 2.533E-003 2.893E-003 3.301E-003 3.753E-003	465.00 nm	2.511E-001 2.408E-001 2.299E-001 2.184E-001 2.068E-001	545.00 nm	3.597E-001 3.741E-001 3.886E-001 4.034E-001 4.183E-001	625.00 nm	7.514E-001 7.296E-001 7.076E-001 6.856E-001 6.638E-001	705.00 nm	8.111E-003 7.582E-003 7.089E-003 6.627E-003 6.195E-003
390.00 nm	4.243E-003 4.762E-003 5.330E-003 5.979E-003 6.741E-003	470.00 nm	1.954E-001 1.842E-001 1.733E-001 1.627E-001 1.523E-001	550.00 nm	4.335E-001 4.488E-001 4.643E-001 4.801E-001 4.960E-001	630.00 nm	6.424E-001 6.215E-001 6.011E-001 5.811E-001 5.614E-001	710.00 nm	5.790E-003 5.410E-003 5.053E-003 4.718E-003 4.404E-003
395.00 nm	7.650E-003 8.751E-003 1.003E-002 1.142E-002 1.287E-002	475.00 nm	1.421E-001 1.322E-001 1.226E-001 1.133E-001 1.043E-001	555.00 nm	5.121E-001 5.283E-001 5.447E-001 5.612E-001 5.778E-001	635.00 nm	5.419E-001 5.226E-001 5.035E-001 4.847E-001 4.662E-001	715.00 nm	4.109E-003 3.834E-003 3.576E-003 3.334E-003 3.109E-003
400.00 nm	1.431E-002 1.570E-002 1.715E-002 1.878E-002 2.075E-002	480.00 nm	9.564E-002 8.730E-002 7.931E-002 7.172E-002 6.458E-002	560.00 nm	5.945E-001 6.112E-001 6.280E-001 6.448E-001 6.616E-001	640.00 nm	4.479E-001 4.299E-001 4.121E-001 3.946E-001 3.775E-001	720.00 nm	2.899E-003 2.704E-003 2.523E-003 2.354E-003 2.197E-003
405.00 nm	2.319E-002 2.621E-002 2.978E-002 3.388E-002 3.847E-002	485.00 nm	5.795E-002 5.186E-002 4.628E-002 4.115E-002 3.641E-002	565.00 nm	6.784E-001 6.952E-001 7.121E-001 7.288E-001 7.455E-001	645.00 nm	3.608E-001 3.445E-001 3.285E-001 3.130E-001 2.980E-001	725.00 nm	2.049E-003 1.911E-003 1.781E-003 1.660E-003 1.546E-003
410.00 nm	4.351E-002 4.900E-002 5.502E-002 6.172E-002 6.921E-002	490.00 nm	3.201E-002 2.792E-002 2.414E-002 2.069E-002 1.754E-002	570.00 nm	7.621E-001 7.785E-001 7.948E-001 8.109E-001 8.268E-001	650.00 nm	2.835E-001 2.695E-001 2.561E-001 2.432E-001 2.307E-001	730.00 nm	1.440E-003 1.340E-003 1.246E-003 1.158E-003 1.076E-003
415.00 nm	7.763E-002 8.696E-002 9.718E-002 1.084E-001 1.208E-001	495.00 nm	1.470E-002 1.216E-002 9.920E-003 7.967E-003 6.296E-003	575.00 nm	8.425E-001 8.579E-001 8.731E-001 8.879E-001 9.023E-001	655.00 nm	2.187E-001 2.071E-001 1.959E-001 1.852E-001 1.748E-001	735.00 nm	1.000E-003 9.290E-004 8.620E-004 8.010E-004 7.430E-004
420.00 nm	1.344E-001 1.494E-001 1.654E-001 1.820E-001 1.986E-001	500.00 nm	4.900E-003 3.777E-003 2.945E-003 2.425E-003 2.236E-003	580.00 nm	9.163E-001 9.298E-001 9.428E-001 9.553E-001 9.672E-001	660.00 nm	1.649E-001 1.554E-001 1.462E-001 1.375E-001 1.291E-001	740.00 nm	6.900E-004 6.410E-004 5.950E-004 5.520E-004 5.120E-004
425.00 nm	2.148E-001 2.302E-001 2.449E-001 2.588E-001 2.718E-001	505.00 nm	2.400E-003 2.926E-003 3.837E-003 5.175E-003 6.982E-003	585.00 nm	9.786E-001 9.894E-001 9.995E-001 1.009E+000 1.018E+000	665.00 nm	1.212E-001 1.136E-001 1.065E-001 9.969E-002 9.333E-002	745.00 nm	4.760E-004 4.420E-004 4.120E-004 3.830E-004 3.570E-004
430.00 nm	2.839E-001 2.949E-001 3.049E-001 3.138E-001 3.216E-001	510.00 nm	9.300E-003 1.215E-002 1.554E-002 1.948E-002 2.399E-002	590.00 nm	1.026E+000 1.034E+000 1.041E+000 1.047E+000 1.052E+000	670.00 nm	8.740E-002 8.190E-002 7.680E-002 7.200E-002 6.769E-002	750.00 nm	3.320E-004 3.100E-004 2.890E-004 2.700E-004 2.520E-004
435.00 nm	3.285E-001 3.344E-001 3.392E-001 3.431E-001 3.461E-001	515.00 nm	2.910E-002 3.482E-002 4.112E-002 4.799E-002 5.538E-002	595.00 nm	1.057E+000 1.060E+000 1.062E+000 1.063E+000 1.063E+000	675.00 nm	6.360E-002 5.981E-002 5.628E-002 5.297E-002 4.982E-002	755.00 nm	2.350E-004 2.190E-004 2.050E-004 1.910E-004 1.780E-004
440.00 nm	3.483E-001 3.496E-001 3.501E-001 3.500E-001 3.493E-001	520.00 nm	6.327E-002 7.164E-002 8.046E-002 8.974E-002 9.946E-002	600.00 nm	1.062E+000 1.061E+000 1.058E+000 1.055E+000 1.051E+000	680.00 nm	4.677E-002 4.378E-002 4.088E-002 3.807E-002 3.541E-002	760.00 nm	1.660E-004 1.550E-004 1.450E-004 1.350E-004 1.260E-004
445.00 nm	3.481E-001 3.464E-001 3.443E-001 3.418E-001 3.391E-001	525.00 nm	1.096E-001 1.202E-001 1.311E-001 1.424E-001 1.539E-001	605.00 nm	1.046E+000 1.039E+000 1.031E+000 1.023E+000 1.013E+000	685.00 nm	3.290E-002 3.056E-002 2.838E-002 2.635E-002 2.445E-002	765.00 nm	1.170E-004 1.100E-004 1.020E-004 9.500E-005 8.900E-005
450.00 nm	3.362E-001 3.332E-001 3.300E-001 3.266E-001 3.229E-001	530.00 nm	1.655E-001 1.773E-001 1.891E-001 2.012E-001 2.134E-001	610.00 nm	1.003E+000 9.914E-001 9.793E-001 9.665E-001 9.528E-001	690.00 nm	2.270E-002 2.108E-002 1.960E-002 1.824E-002 1.699E-002	770.00 nm	8.300E-005 7.800E-005 7.200E-005 6.700E-005 6.300E-005
455.00 nm	3.187E-001 3.140E-001 3.089E-001 3.033E-001 2.973E-001	535.00 nm	2.258E-001 2.383E-001 2.511E-001 2.640E-001 2.771E-001	615.00 nm	9.384E-001 9.232E-001 9.072E-001 8.905E-001 8.729E-001	695.00 nm	1.584E-002 1.479E-002 1.383E-002 1.295E-002 1.213E-002	775.00 nm	5.900E-005 5.500E-005 5.100E-005 4.800E-005 4.400E-005
						780.00 nm	4.200E-005		

Y-bar Spectral Tristimulus Values from 1931 CIE Standard Observer
(380 nm to 780 nm @ 1 nm intervals)

380.00 nm	3.900E-005 4.300E-005 4.700E-005 5.200E-005 5.700E-005	460.00 nm	6.000E-002 6.260E-002 6.528E-002 6.804E-002 7.091E-002	540.00 nm	9.540E-001 9.603E-001 9.660E-001 9.713E-001 9.760E-001	620.00 nm	3.810E-001 3.689E-001 3.568E-001 3.448E-001 3.328E-001	700.00 nm	4.102E-003 3.838E-003 3.589E-003 3.354E-003 3.134E-003
385.00 nm	6.400E-005 7.200E-005 8.200E-005 9.400E-005 1.060E-004	465.00 nm	7.390E-002 7.702E-002 8.027E-002 8.367E-002 8.723E-002	545.00 nm	9.803E-001 9.841E-001 9.874E-001 9.903E-001 9.928E-001	625.00 nm	3.210E-001 3.093E-001 2.979E-001 2.866E-001 2.756E-001	705.00 nm	2.929E-003 2.738E-003 2.560E-003 2.393E-003 2.237E-003
390.00 nm	1.200E-004 1.350E-004 1.510E-004 1.700E-004 1.920E-004	470.00 nm	9.098E-002 9.492E-002 9.905E-002 1.034E-001 1.079E-001	550.00 nm	9.950E-001 9.967E-001 9.981E-001 9.991E-001 9.997E-001	630.00 nm	2.650E-001 2.548E-001 2.449E-001 2.353E-001 2.261E-001	710.00 nm	2.091E-003 1.954E-003 1.825E-003 1.704E-003 1.590E-003
395.00 nm	2.170E-004 2.470E-004 2.810E-004 3.190E-004 3.570E-004	475.00 nm	1.126E-001 1.175E-001 1.227E-001 1.280E-001 1.335E-001	555.00 nm	1.000E+000 9.999E-001 9.993E-001 9.983E-001 9.969E-001	635.00 nm	2.170E-001 2.082E-001 1.995E-001 1.912E-001 1.830E-001	715.00 nm	1.484E-003 1.384E-003 1.291E-003 1.204E-003 1.123E-003
400.00 nm	3.960E-004 4.340E-004 4.730E-004 5.180E-004 5.720E-004	480.00 nm	1.390E-001 1.447E-001 1.505E-001 1.565E-001 1.627E-001	560.00 nm	9.950E-001 9.926E-001 9.897E-001 9.864E-001 9.827E-001	640.00 nm	1.750E-001 1.672E-001 1.596E-001 1.523E-001 1.451E-001	720.00 nm	1.047E-003 9.770E-004 9.110E-004 8.500E-004 7.930E-004
405.00 nm	6.400E-004 7.250E-004 8.260E-004 9.410E-004 1.070E-003	485.00 nm	1.693E-001 1.762E-001 1.836E-001 1.913E-001 1.994E-001	565.00 nm	9.786E-001 9.741E-001 9.692E-001 9.639E-001 9.581E-001	645.00 nm	1.382E-001 1.315E-001 1.250E-001 1.188E-001 1.128E-001	725.00 nm	7.400E-004 6.900E-004 6.430E-004 5.990E-004 5.580E-004
410.00 nm	1.210E-003 1.362E-003 1.531E-003 1.720E-003 1.935E-003	490.00 nm	2.080E-001 2.171E-001 2.267E-001 2.369E-001 2.475E-001	570.00 nm	9.520E-001 9.454E-001 9.385E-001 9.312E-001 9.235E-001	650.00 nm	1.070E-001 1.015E-001 9.619E-002 9.112E-002 8.627E-002	730.00 nm	5.200E-004 4.840E-004 4.500E-004 4.180E-004 3.890E-004
415.00 nm	2.180E-003 2.455E-003 2.764E-003 3.118E-003 3.526E-003	495.00 nm	2.586E-001 2.702E-001 2.823E-001 2.951E-001 3.086E-001	575.00 nm	9.154E-001 9.070E-001 8.983E-001 8.892E-001 8.798E-001	655.00 nm	8.160E-002 7.712E-002 7.283E-002 6.871E-002 6.477E-002	735.00 nm	3.610E-004 3.350E-004 3.110E-004 2.890E-004 2.680E-004
420.00 nm	4.000E-003 4.546E-003 5.159E-003 5.829E-003 6.546E-003	500.00 nm	3.230E-001 3.384E-001 3.547E-001 3.717E-001 3.893E-001	580.00 nm	8.700E-001 8.599E-001 8.494E-001 8.386E-001 8.276E-001	660.00 nm	6.100E-002 5.740E-002 5.396E-002 5.067E-002 4.755E-002	740.00 nm	2.490E-004 2.310E-004 2.150E-004 1.990E-004 1.850E-004
425.00 nm	7.300E-003 8.087E-003 8.909E-003 9.768E-003 1.066E-002	505.00 nm	4.073E-001 4.256E-001 4.443E-001 4.634E-001 4.829E-001	585.00 nm	8.163E-001 8.048E-001 7.931E-001 7.812E-001 7.692E-001	665.00 nm	4.458E-002 4.176E-002 3.909E-002 3.656E-002 3.420E-002	745.00 nm	1.720E-004 1.600E-004 1.490E-004 1.380E-004 1.290E-004
430.00 nm	1.160E-002 1.257E-002 1.358E-002 1.463E-002 1.571E-002	510.00 nm	5.030E-001 5.236E-001 5.445E-001 5.657E-001 5.870E-001	590.00 nm	7.570E-001 7.448E-001 7.324E-001 7.200E-001 7.075E-001	670.00 nm	3.200E-002 2.996E-002 2.808E-002 2.633E-002 2.471E-002	750.00 nm	1.200E-004 1.120E-004 1.040E-004 9.700E-005 9.100E-005
435.00 nm	1.684E-002 1.801E-002 1.921E-002 2.045E-002 2.172E-002	515.00 nm	6.082E-001 6.293E-001 6.503E-001 6.709E-001 6.908E-001	595.00 nm	6.949E-001 6.822E-001 6.695E-001 6.567E-001 6.438E-001	675.00 nm	2.320E-002 2.180E-002 2.050E-002 1.928E-002 1.812E-002	755.00 nm	8.500E-005 7.900E-005 7.400E-005 6.900E-005 6.400E-005
440.00 nm	2.300E-002 2.429E-002 2.561E-002 2.696E-002 2.835E-002	520.00 nm	7.100E-001 7.282E-001 7.455E-001 7.620E-001 7.778E-001	600.00 nm	6.310E-001 6.182E-001 6.053E-001 5.925E-001 5.796E-001	680.00 nm	1.700E-002 1.590E-002 1.484E-002 1.381E-002 1.284E-002	760.00 nm	6.000E-005 5.600E-005 5.200E-005 4.900E-005 4.500E-005
445.00 nm	2.980E-002 3.131E-002 3.288E-002 3.452E-002 3.623E-002	525.00 nm	7.932E-001 8.081E-001 8.225E-001 8.363E-001 8.495E-001	605.00 nm	5.668E-001 5.540E-001 5.411E-001 5.284E-001 5.156E-001	685.00 nm	1.192E-002 1.107E-002 1.027E-002 9.533E-003 8.846E-003	765.00 nm	4.200E-005 4.000E-005 3.700E-005 3.400E-005 3.200E-005
450.00 nm	3.800E-002 3.985E-002 4.177E-002 4.377E-002 4.584E-002	530.00 nm	8.620E-001 8.738E-001 8.850E-001 8.955E-001 9.054E-001	610.00 nm	5.030E-001 4.905E-001 4.780E-001 4.657E-001 4.534E-001	690.00 nm	8.210E-003 7.624E-003 7.085E-003 6.591E-003 6.138E-003	770.00 nm	3.000E-005 2.800E-005 2.600E-005 2.400E-005 2.300E-005
455.00 nm	4.800E-002 5.024E-002 5.257E-002 5.498E-002 5.746E-002	535.00 nm	9.149E-001 9.237E-001 9.321E-001 9.399E-001 9.472E-001	615.00 nm	4.412E-001 4.291E-001 4.170E-001 4.050E-001 3.930E-001	695.00 nm	5.723E-003 5.343E-003 4.996E-003 4.676E-003 4.380E-003	775.00 nm	2.100E-005 2.000E-005 1.800E-005 1.700E-005 1.600E-005
								780.00 nm	1.500E-005

Z-bar Spectral Tristimulus Values from 1931 CIE Standard Observer
(380 nm to 780 nm @ 1 nm intervals)

380.00 nm	6.450E-003 7.083E-003 7.745E-003 8.501E-003 9.415E-003	460.00 nm	1.669E+000 1.648E+000 1.623E+000 1.596E+000 1.565E+000	540.00 nm	2.030E-002 1.872E-002 1.724E-002 1.586E-002 1.459E-002	620.00 nm	1.900E-004 1.740E-004 1.560E-004 1.360E-004 1.170E-004	700.00 nm	0.000E+000 0.000E+000 0.000E+000 0.000E+000 0.000E+000
385.00 nm	1.055E-002 1.197E-002 1.366E-002 1.559E-002 1.773E-002	465.00 nm	1.528E+000 1.486E+000 1.440E+000 1.390E+000 1.339E+000	545.00 nm	1.340E-002 1.231E-002 1.130E-002 1.038E-002 9.529E-003	625.00 nm	1.000E-004 8.600E-005 7.500E-005 6.500E-005 5.700E-005	705.00 nm	0.000E+000 0.000E+000 0.000E+000 0.000E+000 0.000E+000
390.00 nm	2.005E-002 2.251E-002 2.520E-002 2.828E-002 3.190E-002	470.00 nm	1.288E+000 1.237E+000 1.188E+000 1.139E+000 1.090E+000	550.00 nm	8.750E-003 8.035E-003 7.382E-003 6.785E-003 6.243E-003	630.00 nm	5.000E-005 4.400E-005 3.900E-005 3.600E-005 3.300E-005	710.00 nm	0.000E+000 0.000E+000 0.000E+000 0.000E+000 0.000E+000
395.00 nm	3.621E-002 4.144E-002 4.750E-002 5.412E-002 6.100E-002	475.00 nm	1.042E+000 9.942E-001 9.473E-001 9.015E-001 8.566E-001	555.00 nm	5.750E-003 5.304E-003 4.900E-003 4.534E-003 4.202E-003	635.00 nm	3.000E-005 2.800E-005 2.600E-005 2.400E-005 2.200E-005	715.00 nm	0.000E+000 0.000E+000 0.000E+000 0.000E+000 0.000E+000
400.00 nm	6.785E-002 7.449E-002 8.136E-002 8.915E-002 9.854E-002	480.00 nm	8.130E-001 7.705E-001 7.294E-001 6.899E-001 6.521E-001	560.00 nm	3.900E-003 3.623E-003 3.371E-003 3.141E-003 2.935E-003	640.00 nm	2.000E-005 1.800E-005 1.600E-005 1.400E-005 1.200E-005	720.00 nm	0.000E+000 0.000E+000 0.000E+000 0.000E+000 0.000E+000
405.00 nm	1.102E-001 1.246E-001 1.417E-001 1.613E-001 1.833E-001	485.00 nm	6.162E-001 5.823E-001 5.504E-001 5.203E-001 4.920E-001	565.00 nm	2.750E-003 2.585E-003 2.439E-003 2.309E-003 2.197E-003	645.00 nm	1.000E-005 8.000E-006 5.000E-006 3.000E-006 1.000E-006	725.00 nm	0.000E+000 0.000E+000 0.000E+000 0.000E+000 0.000E+000
410.00 nm	2.074E-001 2.337E-001 2.626E-001 2.948E-001 3.308E-001	490.00 nm	4.652E-001 4.399E-001 4.162E-001 3.939E-001 3.729E-001	570.00 nm	2.100E-003 2.018E-003 1.948E-003 1.890E-003 1.841E-003	650.00 nm	0.000E+000 0.000E+000 0.000E+000 0.000E+000 0.000E+000	730.00 nm	0.000E+000 0.000E+000 0.000E+000 0.000E+000 0.000E+000
415.00 nm	3.713E-001 4.162E-001 4.655E-001 5.197E-001 5.795E-001	495.00 nm	3.533E-001 3.349E-001 3.176E-001 3.013E-001 2.862E-001	575.00 nm	1.800E-003 1.766E-003 1.738E-003 1.711E-003 1.683E-003	655.00 nm	0.000E+000 0.000E+000 0.000E+000 0.000E+000 0.000E+000	735.00 nm	0.000E+000 0.000E+000 0.000E+000 0.000E+000 0.000E+000
420.00 nm	6.456E-001 7.185E-001 7.967E-001 8.778E-001 9.594E-001	500.00 nm	2.720E-001 2.588E-001 2.465E-001 2.348E-001 2.235E-001	580.00 nm	1.650E-003 1.610E-003 1.564E-003 1.514E-003 1.459E-003	660.00 nm	0.000E+000 0.000E+000 0.000E+000 0.000E+000 0.000E+000	740.00 nm	0.000E+000 0.000E+000 0.000E+000 0.000E+000 0.000E+000
425.00 nm	1.039E+000 1.115E+000 1.188E+000 1.258E+000 1.324E+000	505.00 nm	2.123E-001 2.012E-001 1.901E-001 1.792E-001 1.686E-001	585.00 nm	1.400E-003 1.337E-003 1.270E-003 1.205E-003 1.147E-003	665.00 nm	0.000E+000 0.000E+000 0.000E+000 0.000E+000 0.000E+000	745.00 nm	0.000E+000 0.000E+000 0.000E+000 0.000E+000 0.000E+000
430.00 nm	1.386E+000 1.443E+000 1.495E+000 1.542E+000 1.585E+000	510.00 nm	1.582E-001 1.481E-001 1.384E-001 1.290E-001 1.201E-001	590.00 nm	1.100E-003 1.069E-003 1.049E-003 1.036E-003 1.021E-003	670.00 nm	0.000E+000 0.000E+000 0.000E+000 0.000E+000 0.000E+000	750.00 nm	0.000E+000 0.000E+000 0.000E+000 0.000E+000 0.000E+000
435.00 nm	1.623E+000 1.656E+000 1.685E+000 1.710E+000 1.730E+000	515.00 nm	1.117E-001 1.039E-001 9.667E-002 8.998E-002 8.385E-002	595.00 nm	1.000E-003 9.690E-004 9.300E-004 8.870E-004 8.430E-004	675.00 nm	0.000E+000 0.000E+000 0.000E+000 0.000E+000 0.000E+000	755.00 nm	0.000E+000 0.000E+000 0.000E+000 0.000E+000 0.000E+000
440.00 nm	1.747E+000 1.760E+000 1.770E+000 1.776E+000 1.780E+000	520.00 nm	7.825E-002 7.321E-002 6.868E-002 6.457E-002 6.079E-002	600.00 nm	8.000E-004 7.610E-004 7.240E-004 6.860E-004 6.450E-004	680.00 nm	0.000E+000 0.000E+000 0.000E+000 0.000E+000 0.000E+000	760.00 nm	0.000E+000 0.000E+000 0.000E+000 0.000E+000 0.000E+000
445.00 nm	1.783E+000 1.783E+000 1.782E+000 1.779E+000 1.776E+000	525.00 nm	5.725E-002 5.390E-002 5.075E-002 4.775E-002 4.490E-002	605.00 nm	6.000E-004 5.480E-004 4.920E-004 4.350E-004 3.830E-004	685.00 nm	0.000E+000 0.000E+000 0.000E+000 0.000E+000 0.000E+000	765.00 nm	0.000E+000 0.000E+000 0.000E+000 0.000E+000 0.000E+000
450.00 nm	1.772E+000 1.768E+000 1.764E+000 1.759E+000 1.752E+000	530.00 nm	4.216E-002 3.951E-002 3.694E-002 3.446E-002 3.209E-002	610.00 nm	3.400E-004 3.070E-004 2.830E-004 2.650E-004 2.520E-004	690.00 nm	0.000E+000 0.000E+000 0.000E+000 0.000E+000 0.000E+000	770.00 nm	0.000E+000 0.000E+000 0.000E+000 0.000E+000 0.000E+000
455.00 nm	1.744E+000 1.734E+000 1.721E+000 1.706E+000 1.689E+000	535.00 nm	2.984E-002 2.771E-002 2.569E-002 2.379E-002 2.199E-002	615.00 nm	2.400E-004 2.300E-004 2.210E-004 2.120E-004 2.020E-004	695.00 nm	0.000E+000 0.000E+000 0.000E+000 0.000E+000 0.000E+000	775.00 nm	0.000E+000 0.000E+000 0.000E+000 0.000E+000 0.000E+000
							780.00 nm	0.000E+000	